

PONTIFICIA UNIVERSIDAD CATÓLICA DEL PERÚ

ESCUELA DE POSGRADO



Quantum Deletion: Photonic Simulation and relevance as No-Go Theorem

A thesis in candidacy for the degree of Master of Science in Physics
presented by:

Giancarlo Gatti Alvarez

Advisor:

Prof. Francisco de Zela

Jury:

Prof. XXXX

Prof. YYYY

Lima, 2016

To my parents and family, for the unconditional care.

To my godfather, for the NASA acceptance letter.

To everyone who heard me rant about the No-Deleting Theorem.

Quantum Deletion: Photonic Simulation and relevance as No-Go Theorem

Giancarlo Gatti Alvarez

Summary

This thesis discusses the No-Deleting Theorem in the context of quantum mechanics, and from an informational and thermodynamic point of view. The theorem is proved, and distinction is made between deletion and erasure.

Erasure is further discussed through Maxwell's Demon and Landauer's principle, which are linked to one another by the Second Law of Thermodynamics. This leads to relate erasure with measurement and work.

A setup for deletion simulation is proposed by use of linear optics supplemented by processes such as spontaneous parametric down-conversion.

Finally, the No-Deleting Theorem is compared to other No-Go Theorems, and implication relations are proved (demonstrated) between it, the No-Signalling Theorem and the Second Law of Thermodynamics.

Maestría en Física

Borrado Cuántico: Simulación Fotónica y relevancia como Teorema de Imposibilidad

Giancarlo Gatti Alvarez

Código: 20084366

Propuesto para el grado de Magíster en Física

Resumen

Esta tesis discute el Teorema de No-Borrado en el contexto de la mecánica cuántica, desde un punto de vista informacional y termodinámico. Se realiza la prueba del teorema, y se hace distinción entre borrado cuántico (*deletion*) y borrado (*erasure*).

Se discute el borrado (*erasure*) a mayor profundidad a través del Demonio de Maxwell y el Principio de Landauer, vinculados entre sí por la Segunda Ley de la Termodinámica. Esto conduce a relacionar el concepto de borrado (*erasure*) con medición y trabajo.

Se propone un montaje experimental que sirve como simulación de un proceso de borrado cuántico (*deletion*), a través del uso de óptica lineal suplementada por procesos como la conversión paramétrica espontánea descendiente.

Finalmente, se compara al Teorema de No-Borrado con otros Teoremas de Imposibilidad, y se demuestran las relaciones de implicancia entre este teorema, el de No-Comunicación y la Segunda Ley de la Termodinámica.

Acknowledgments

The results presented in this thesis are largely based on work done for an article, in collaboration with fellow GROC-PUCP (Grupo de Óptica Cuántica - Pontificia Universidad Católica del Perú) researcher, Diego Barberena, and Julen Pedernales and Mikel Sanz, researchers from QUTIS-UPV (Quantum Technologies for Information Science - Universidad del País Vasco). Special thanks to Prof. Enrique Solano (QUTIS-UPV) supervisor of the article work, and to Prof. De Zela (GROC-PUCP) advisor of this thesis, who helped with corrections along the way.

This Thesis was done under a grant given by CIENCIA ACTIVA-CONCYTEC.

Published material accompanying this thesis work

The following paper was prepared while developing the present work. It reports a tool that can be used in experimental tests of some topics addressed in this thesis:

D. Barberena, G. Gatti, and F. D. Zela, Experimental demonstration of a secondary source of partially polarized states, *J. Opt. Soc. Am. A* 32 (2015), 697-700.

Contents

Summary	iii
Resumen	iv
Acknowledgments	v
1 Introduction	2
2 Review	3
2.1 No-Deleting Theorem	3
2.2 No-Cloning Theorem	5
2.3 Second Law of Thermodynamics	6
2.3.1 Maxwell’s Demon	8
2.3.2 Landauer’s Principle	10
2.4 Parametric Down-Conversion	13
3 Simulation	14
3.1 Modelling a Deleter	14
3.2 Modelling a BBO	17
3.3 Simulating a Deleter without postselection	18
3.4 Simulating a Deleter for an unknown state	25
4 Relevance as No-Go Theorem	33
4.1 Deleter and Signalling	33
4.2 Deleter and Second Law	36
4.2.1 Entropy in a Deleter	36
4.2.2 From Second Law to No-Deleting	40
4.2.3 From No-Deleting to Second Law	42
5 Conclusions	50
References	52

List of Figures

3.1	Deleter as Path-Merger Beam-Splitter	17
3.2	Second-order Interference with two BBO crystals	19
4.1	Franson interferometer	34
4.2	Heat Engine	42
4.3	Coupled Heat Engine	44
4.4	Unphysical heat-to-work Engine	44
4.5	Tweaked quantum teleportation protocol	47
4.6	Deleter Engine	48

Chapter 1

Introduction

There has been an increasing interest in the relation between Quantum Mechanics and information. General theorems of Quantum Mechanics directly address concepts such as information deletion, cloning, and cryptography.

In fact, a reformulation of the quantum formalism in terms of a theory of information has been considered [1] [2] [3]. It is in this context that we will be specifically interested in the No-Deleting Theorem, a theorem implied by the unitarity condition of Quantum Mechanics. However, we will study this theorem alone, and not as an implication of unitarity, as it is more easily related with information than the unitarity condition.

For this matter, this thesis will approach Quantum Deletion in two ways. On one hand, we will propose a photonic simulation of a deletion process, to study what is the closest we can actually get to a quantum deletion evolution. On the other hand, as has been done previously [3], we will promote the No-Deleting Theorem to a principle, to pinpoint its relevance in relation with other No-Go Theorems.

Chapter 2

Review

2.1 No-Deleting Theorem

In the context of classical information, erasure of a bit of information is a feasible operation, albeit with a minimum $k_B T \ln(2)$ heat released (k_B is the Boltzmann constant and T the temperature of the system in Kelvin), given by Landauer's Principle [4]. To erase means to reset an arbitrary bit in a system to a constant (known) state, and it is considered an irreversible operation [5].

Upon entering the domain of Quantum Mechanics, however, when we refer to two-level systems, we speak not only of systems that can take one out of two possible states, but also any possible superposition of those states (which we write down as normalized complex-coefficient linear combinations of the states). Still, despite having an infinite number of possible states, when doing measurements on one of these systems, the result will always be one out of two (and no more than two) states.

Taking these superposition states into account, another kind of information can be defined based on these physical systems: quantum information, with the qubit—a two-level system with the possibility of superposition—as unit of measurement. One may thus wonder if an arbitrary qubit can be reset to a constant state in an irreversible manner (deleted), or if it can be copied.

We will now prove that Quantum Mechanics forbids arbitrary qubits from being deleted, even against a copy. The general structure of our proof is taken from [6].

Let $|\psi\rangle$ be an unknown quantum state in some Hilbert space. Then, we can prove that there is no linear unitary transformation such that:

$$|\psi\rangle_A |\psi\rangle_B |A\rangle_C \rightarrow |\psi\rangle_A |0\rangle_B |A'_\psi\rangle_C, \quad (2.1)$$

where $|A\rangle$ and $|A'_\psi\rangle$ are ancillas, and $|\psi\rangle$ can not be reconstructed from $|A'_\psi\rangle$ by a

constant (ψ -independent) transformation.

Without loss of generality, we will consider two-dimensional Hilbert spaces and let $|\psi\rangle = \alpha|0\rangle + \beta|1\rangle$. Transformation 2.1 would require that:

$$\begin{aligned} |0\rangle_A|0\rangle_B|A\rangle_C &\rightarrow |0\rangle_A|0\rangle_B|A_0\rangle_C \\ |1\rangle_A|1\rangle_B|A\rangle_C &\rightarrow |1\rangle_A|0\rangle_B|A_1\rangle_C \end{aligned} \quad (2.2)$$

By linearity, we would know how the span of $|0\rangle_A|0\rangle_B|A\rangle_C$ and $|1\rangle_A|1\rangle_B|A\rangle_C$ transforms, but we would not know anything about how any other term transforms. Since the transformation is linear, the result will always be a superposition of pure states, so we can always write a (for now) unknown output state $|\phi\rangle_{ABC}$. Thanks to unitarity, we do know that the output will be normalized if the input is too. This way, for a normalized vector $|\psi\rangle = \alpha|0\rangle + \beta|1\rangle$, we would have:

$$\begin{aligned} |\psi\rangle_A|\psi\rangle_B|A\rangle_C &= \left(\alpha^2|0\rangle_A|0\rangle_B + \beta^2|1\rangle_A|1\rangle_B + \alpha\beta(|0\rangle_A|1\rangle_B + |1\rangle_A|0\rangle_B) \right) |A\rangle_C \\ &\rightarrow \alpha^2|0\rangle_A|0\rangle_B|A_0\rangle_C + \beta^2|1\rangle_A|0\rangle_B|A_1\rangle_C + \sqrt{2}\alpha\beta|\phi\rangle_{ABC} \end{aligned} \quad (2.3)$$

Here, we are writing $|\phi\rangle_{ABC}$ as the transformation of $\frac{1}{\sqrt{2}}(|0\rangle_A|1\rangle_B + |1\rangle_A|0\rangle_B)|A\rangle_C$.

Let us note that, if transformation 2.1 is to hold, the total output should be equal to $(\alpha|0\rangle_A|0\rangle_B + \beta|1\rangle_A|0\rangle_B)|A'_\psi\rangle_C$. We have, then:

$$|\phi\rangle_{ABC} \stackrel{!}{=} \frac{1}{\sqrt{2}} \left(|0\rangle_A|0\rangle_B \frac{1}{\beta} \left(|A'_\psi\rangle_C - \alpha|A_0\rangle_C \right) + |1\rangle_A|0\rangle_B \frac{1}{\alpha} \left(|A'_\psi\rangle_C - \beta|A_1\rangle_C \right) \right) \quad (2.4)$$

But $|\phi\rangle_{ABC}$ is independent of α or β , since it is merely the evolution of a fixed state. Thus, each linearly independent term of 2.4 should be equal to a (different) constant state (we will name them $|c_1\rangle_C$ and $|c_2\rangle_C$):

$$\begin{aligned} \frac{1}{\beta} \left(|A'_\psi\rangle_C - \alpha|A_0\rangle_C \right) &= |c_1\rangle_C \\ \frac{1}{\alpha} \left(|A'_\psi\rangle_C - \beta|A_1\rangle_C \right) &= |c_2\rangle_C \end{aligned} \quad (2.5)$$

This is the same as:

$$\begin{aligned} |A'_\psi\rangle_C &= \alpha|A_0\rangle_C + \beta|c_1\rangle_C \\ |A'_\psi\rangle_C &= \alpha|c_2\rangle_C + \beta|A_1\rangle_C \end{aligned} \quad (2.6)$$

It is now easy to note that $|c_1\rangle_C = |A_1\rangle_C$ and $|c_2\rangle_C = |A_0\rangle_C$, which leads us to:

$$|A'_\psi\rangle_C = \alpha|A_0\rangle_C + \beta|A_1\rangle_C \quad (2.7)$$

Since the evolution is unitary, this state must be normalized, so $|A_0\rangle_C$ and $|A_1\rangle_C$ must be orthogonal and form a basis, because their amplitudes are normalized only in that case. Let U be the transformation that maps the basis $\{|0\rangle, |1\rangle\}$ to $\{|A_0\rangle, |A_1\rangle\}$.

Thus, linear and unitary transformations of the form 2.1 must also be of this form:

$$|\psi\rangle_A|\psi\rangle_B|A\rangle_C \rightarrow |\psi\rangle_A|0\rangle_B U|\psi\rangle_C \quad (2.8)$$

This means that the information that was encoded through $|\psi\rangle$ in the initial state remains available in the transformed state. Thus, there can not be a linear and unitary transformation in which quantum information is lost, that is, deletion is forbidden by Quantum Mechanics.

Not only that. To (irreversibly) delete an arbitrary qubit would result in the possibility of faster-than-light communication [3] [7], something forbidden by relativity.

The question is now open: why is it that classical information can be *irreversibly* erased –albeit with a heat-release cost– but quantum information can not be (irreversibly) deleted? We will address this question later on.

2.2 No-Cloning Theorem

The laws of Quantum Mechanics also forbid copying (cloning) an arbitrary qubit [8] [9]. Consider the following proof:

Let $|\psi\rangle$ be an unknown quantum state in some Hilbert space. Then, we can prove that there is no linear unitary transformation such that:

$$|\psi\rangle_A|0\rangle_B|A\rangle_C \rightarrow |\psi\rangle_A|\psi\rangle_B|A'_\psi\rangle_C, \quad (2.9)$$

where $|A\rangle_C$ must be independent of $|\psi\rangle$.

Once again, without loss of generality, we consider two-dimensional Hilbert spaces and let $|\psi\rangle = \alpha|0\rangle + \beta|1\rangle$. This time, transformation 2.9 requires that:

$$\begin{aligned} |0\rangle_A|0\rangle_B|A\rangle_C &\rightarrow |0\rangle_A|0\rangle_B|A_0\rangle_C \\ |1\rangle_A|0\rangle_B|A\rangle_C &\rightarrow |1\rangle_A|1\rangle_B|A_1\rangle_C \end{aligned} \quad (2.10)$$

The input $|\psi\rangle_A|0\rangle_B|A\rangle_C$ is equal to $\alpha|0\rangle_A|0\rangle_B|A\rangle_C + \beta|1\rangle_A|0\rangle_B|A\rangle_C$. Applying 2.10 and considering linearity, it should transform in the following way:

$$|\psi\rangle_A|0\rangle_B|A\rangle_C \rightarrow \alpha|0\rangle_A|0\rangle_B|A_0\rangle_C + \beta|1\rangle_A|1\rangle_B|A_1\rangle_C \quad (2.11)$$

Transformation 2.9 and 2.11 should be equivalent, so their outputs should be the same.

$$|\psi\rangle_A|\psi\rangle_B|A'_\psi\rangle_C \stackrel{!}{=} \alpha|0\rangle_A|0\rangle_B|A_0\rangle_C + \beta|1\rangle_A|1\rangle_B|A_1\rangle_C \quad (2.12)$$

Considering $|\psi\rangle = \alpha|0\rangle + \beta|1\rangle$ and reordering the terms, we get:

$$\begin{aligned} |0\rangle_A|0\rangle_B(\alpha|A\rangle_C - \alpha^2|A'_\psi\rangle_C) + |1\rangle_A|1\rangle_B(\beta|A\rangle_C - \beta^2|A'_\psi\rangle_C) \\ \stackrel{!}{=} \alpha\beta(|1\rangle_A|0\rangle_B + |0\rangle_A|1\rangle_B)|A'_\psi\rangle_C \end{aligned} \quad (2.13)$$

If we project this equation on –say– $|1\rangle_A|0\rangle_B$, we obtain $0 \stackrel{!}{=} \alpha\beta|1\rangle_A|0\rangle_B|A'_\psi\rangle_C$, so we can note that this equation does not hold for arbitrary α and β , that is, for an arbitrary $|\psi\rangle$. Thus, –like deletion– cloning an arbitrary state is forbidden by Quantum Mechanics.

Moreover, cloning also results in the possibility of faster-than-light communication [8].

2.3 Second Law of Thermodynamics

In a way, the founding formulation to the Second Law of Thermodynamics was done by Carnot, without actually calling it a “law of thermodynamics” (as the Laws of Thermodynamics did not exist yet), when deducing that the maximum efficiency a heat engine can have is that given by what we nowadays call the Carnot cycle. His deduction is based on the cycle’s feature of being reversible (a reversed engine is when the transferred amount of both heat and work is the same, but going in the opposite direction).

“Now if there existed any means of using heat preferable to those which we have employed, that is, if it were possible by any method whatever to make the caloric produce a quantity of motive power greater than we have made it produce by our first series of operations, it would suffice to divert a portion of this power in order by the method just indicated to make the caloric of the body B return to the body A from the refrigerator to the furnace, to restore the initial conditions, and thus to be ready to commence again an operation precisely similar to the former, and so on: this would be not only perpetual motion, but an unlimited creation of motive

power without consumption either of caloric or of any other agent whatever. Such a creation is entirely contrary to ideas now accepted, to the laws of mechanics and of sound physics. It is inadmissible. We should then conclude that the maximum of motive power resulting from the employment of steam is also the maximum of motive power realizable by any means whatever.” (Carnot [10]).

As we can see, the argument behind Carnot proposing his cycle’s efficiency as the best possible efficiency for a heat engine is a notion of the Second Law of Thermodynamics, that is, that we can not have *perpetual motion* or “*unlimited creation of motive power*”. This way, we may guess that Carnot’s cycle efficiency is the one that can be achieved by any reversible heat engine, as noted in [11]. It is also worth noting that Carnot also gave a more rigorous demonstration for his proposal, and that our citation is what –in his words– he “considered only as an approximation”.

After Carnot’s, some other formulations of the Second Law were made in terms of work, heat and temperature: the Clausius and Kelvin statements.

“Heat can never pass from a colder to a warmer body without some other change, connected therewith, occurring at the same time” (Clausius statement [12]).

“It is impossible, by means of inanimate material agency, to derive mechanical effect from any portion of matter by cooling it below the temperature of the coldest of the surrounding objects” (Kelvin statement [13]).

These two statements are equivalent, as proved in [14].

It can also be shown that these statements are equivalent to forbidding extraction of work from the heat of a single system in equilibrium (or moving said system out of equilibrium without expense of work). We will now prove it, by considering the relation between this *equilibrium* statement not holding and the Clausius statement not holding:

- Let us have two systems, both in equilibrium, and one colder than the other. Suppose that we extract work from the heat in the colder system. As stated in [14], “the transformation of work into heat is accomplished with 100 percent efficiency” and “can be continued indefinitely”, so we can freely convert this work into heat in the hotter system. This way, we see that if this *equilibrium* statement does not hold, neither does the Clausius statement (or the Kelvin statement, since both are equivalent).
- To prove the equivalence between all the statements, we also need to prove the reciprocal: that the *equilibrium* statement does not hold when the Clausius

(or Kelvin) statement does not hold. Considering again our two systems (one colder than the other), if the Clausius statement did not hold, we would be able to transfer heat from the cold system to the hot system, and then use Carnot’s engine to obtain work from the temperature difference, taking as much heat as was given to the hot system before, so that its net change is zero. The cold system would not get back as much heat as it lost before, because we obtain some of it as work. This way, the total effect is that we have obtained work from the heat of a single system in equilibrium –the cold system–, breaking the *equilibrium* statement.

These two implications are enough to conclude this statement to be equivalent to the Clausius and Kelvin statements. A similar logic can be used to compare Carnot’s *maximum-efficiency* statement with the others, and conclude their equivalence. We will show this later on.

The Second Law of Thermodynamics has many equivalent statements, as we may have noted, but we will be particularly interested in the statement in terms of entropy, as it will open us the door to speak about information. Entropy is a quantity such that its change is equal to the heat change in a system divided by its (absolute) temperature. Like heat, we do not speak of total entropy, but of changes in entropy instead (at least not until we consider the Third Law of Thermodynamics, where crystals are said to have 0 entropy). If the system’s temperature is not constant, differentials are used in this definition.

The Second Law formulation that uses entropy is derived from Clausius’ work [12], and states that the net entropy in a closed system can not decrease. This means that it is constant in reversible processes.

We will be interested in viewing this formulation of the Second Law of Thermodynamics through a more informational point of view. We will do this by referring to Maxwell’s Demon.

2.3.1 Maxwell’s Demon

In 1867, J. C. Maxwell first proposed (albeit not publicly) a thought experiment of how a “being” may be able to break the Second Law of Thermodynamics:

“... if we conceive of a being whose faculties are so sharpened that he can follow every molecule in its course, such a being, whose attributes are as essentially finite as our own, would be able to do what is impossible to us. For we have seen that molecules in a vessel full of air at uniform temperature are moving with velocities by no means uniform, though the mean velocity of any great number of them, arbitrarily

selected, is almost exactly uniform. Now let us suppose that such a vessel is divided into two portions, A and B, by a division in which there is a small hole, and that a being, who can see the individual molecules, opens and closes this hole, so as to allow only the swifter molecules to pass from A to B, and only the slower molecules to pass from B to A. He will thus, without expenditure of work, raise the temperature of B and lower that of A, in contradiction to the second law of thermodynamics.”

In his argument, he proposes a closed system with two compartments (A and B) with gas molecules, initially in equilibrium. The compartments are separated by a wall with a small sliding door between them. Inside of the system, there is a “being” with fast-enough reflexes that slides open the door whenever a fast molecule comes from A, or a slow molecule comes from B. The rest of the time, the door remains closed. Temperature is related to the mean speed of gas molecules, thus the temperature of B would rise while the temperature of A would diminish. Since the door can be slid without the expenditure of work, it seems as if the Second Law of Thermodynamics has been broken: a system in equilibrium has been moved out of equilibrium without (seemingly) any expense of work.

In 1929, Leó Szilárd pointed out that the act of measuring the molecules (determining whether they’re *fast* or *slow*) requires an expenditure of energy. Specifically, “production of $k_B \ln(2)$ units of entropy” per measurement would be enough to compensate the entropy decrease resulting from the Demon’s intervention [15]. Such entropy is equivalent to a heat-release of $k_B T \ln(2)$ units, the very same minimum-heat-release required for the Landauer-erasure process. Szilárd would not have been able to note it, since Landauer’s proposal was made in 1961, but surely this can not be just coincidence.

Measurement processes do not actually need to increase the entropy, as long as they are reversible [4]. This implies that some sort of memory is used to store the measurement information, or else the process would not be reversible. A *Demon* should not be able to do this indefinitely without eventually running out of storage space, or erasing some of the stored information, something that, as shown by Landauer, releases $k_B T \ln(2)$ units of heat. We can also put it this way: it is possible to make measurements without expending entropy (or releasing heat), so long as the measuring apparatus has been previously set into a known state (which can be achieved by measuring the initial state of the measuring apparatus).

Summarizing: To measure one bit of information from a system, a minimum of $k_B \ln(2)$ units of entropy must be taken from it, or those bits must be written in another previously set system. The information we obtain from the system can then be used to extract work from it, using the Maxwell-Demon method. This way,

measurement, i.e, information obtained from a system, can be used to extract work, and the same can be said for the erasure of information (which is something that can be done without the requirement of work if the system is known, i.e, has been measured). There is, then, some kind of equivalence between measuring, erasing and extracting work.

2.3.2 Landauer’s Principle

In the first section we have already referred to Landauer’s Principle, which states that a minimum heat (of $k_B T \ln(2)$) has to be released (into a reservoir at temperature T) in order to erase a bit of information from a system [4]. This Principle can be considered an additional formulation of the Second Law of Thermodynamics, but that is not sufficient reason to dedicate a complete section to it. Instead, Landauer’s Principle will serve us to –in a way– link thermodynamical entropy (and the Second Law of Thermodynamics) with information. We will not establish the link here, but instead offer a proof of the Principle more rigorous than that given by Landauer in the context of quantum theory. Our model and proof is taken from Piechocinska [16], specifically for the “quantum case”.

In the erasure model, we consider a two level atom, such that it begins in the following state:

$$\hat{\rho}_{\text{init}} = \frac{1}{2}|0\rangle\langle 0| + \frac{1}{2}|1\rangle\langle 1| \quad (2.14)$$

This state is a completely arbitrary state. Our aim is for the erasure to turn it into:

$$|0\rangle\langle 0| \quad (2.15)$$

The atom is initially degenerated in energy, that is, there is no energy difference between state $|0\rangle$ and state $|1\rangle$. Let us consider that we momentarily break degeneration of the atom by turning “on and off” a magnetic field. During that time, the system will be in (transitory) contact with a reservoir in thermal equilibrium, which can be, for example, “a photon reservoir of harmonic oscillators”. This way, if -after turning on the magnetic field- the energy difference between the two states of the atom is so big that the photon reservoir can not excite the atom into the higher-energy state, the atom would eventually find itself in the lower-energy state. The magnetic field would then be turned off, and we would cease contact between the atom and reservoir.

After this erasure, the reservoir weakly interacts with an unspecified environ-

ment, which acts as a measurement device. This way, if the reservoir's density matrix (expressed in the energy eigenstate basis) has any non-diagonal elements after the erasure, measurement makes it decohere, i.e, lose those elements.

Let us now write this explicitly. The reservoir is initially in thermal equilibrium, such that its density matrix is:

$$\hat{\rho}_{\hat{H}} = \frac{e^{-\beta\hat{H}}}{\text{Tr}[e^{-\beta\hat{H}}]}, \quad (2.16)$$

where \hat{H} is its Hamiltonian and $\beta = \frac{1}{k_B T}$ (k_B is the Boltzmann constant and T the temperature of the reservoir).

We will consider this reservoir to be initially in a definite energy eigenstate, such that the probability of finding it in the energy eigenstate $|E_n\rangle$ (with energy E_n) is:

$$P_n = \frac{e^{-\beta E_n}}{\sum_m e^{-\beta E_m}} = \frac{e^{-\beta E_n}}{Z} \quad (2.17)$$

We now couple the atom and reservoir, and turn on the magnetic field. After waiting a while, uncoupling them and turning off the magnetic field, the atom ends up in state:

$$\hat{\rho}_{\text{fin}} = |0\rangle\langle 0|, \quad (2.18)$$

where the atom's states $|0\rangle$ and $|1\rangle$ are again degenerated in energy.

After the interaction, the reservoir decoheres and ends up in one of the energy eigenstates $|E_m\rangle$ (of energy E_m), with (unknown) probability P_m .

We will now prove that in this generic case, a minimum of $k_B T \ln(2)$ average heat has to be released into the reservoir.

We first define P_i as $|\langle i|\hat{\rho}_{\text{init}}|i\rangle|^2$ and P_f as $|\langle f|\hat{\rho}_{\text{fin}}|f\rangle|^2$, where i and f can be 0 or 1 (the states of the 2-level system). Note that we are using i and f both as index and tag, so if we ever need to specify, for example, P_0 for the initial atom state, we will need to write P_0^{init} instead. This way, $P_0^{\text{init}} = P_1^{\text{init}} = \frac{1}{2}$, $P_0^{\text{fin}} = 1$ and $P_1^{\text{fin}} = 0$.

With that, let $\Gamma = \ln(P_i) - \ln(P_f) - \beta(E_n - E_m)$. We now calculate the expected value of $\langle e^{-\Gamma} \rangle$:

$$\langle e^{-\Gamma} \rangle = \sum_{n,m,i,f} P_i P_n |\langle f, m|U|i, n\rangle|^2 e^{-\ln(P_i)+\ln(P_f)+\beta(E_n-E_m)}, \quad (2.19)$$

where $|i, n\rangle$ is one of the possible starting states of the atom-reservoir system, $|f, m\rangle$ a possible final state, and U the evolution performed on it.

We use 2.17 and show that:

$$\langle e^{-\Gamma} \rangle = \sum_{n,m,i,f} P_i |\langle f, m | U | i, n \rangle|^2 \frac{e^{-\beta E_n} P_f}{Z P_i} e^{\beta(E_n - E_m)}, \quad (2.20)$$

which is equivalent to:

$$\langle e^{-\Gamma} \rangle = \frac{1}{Z} \sum_{f,m} P_f e^{\beta E_m} \sum_{i,n} |\langle f, m | U | i, n \rangle|^2 \quad (2.21)$$

Due to unitarity of U , we note that $\sum_{i,n} |\langle f, m | U | i, n \rangle|^2 = 1$, and we have:

$$\langle e^{-\Gamma} \rangle = \sum_f P_f \frac{\sum_m e^{\beta E_m}}{Z} = \sum_f P_f \frac{Z}{Z} = \sum_f P_f = 1 \quad (2.22)$$

Due to the convexity of the exponential function, $\langle e^{-\Gamma} \rangle = 1$ implies $\langle -\Gamma \rangle \leq 0$:

$$\langle -\ln(P_i) + \ln(P_f) + \beta(E_n - E_m) \rangle \leq 0 \quad (2.23)$$

We substitute the values of P_i and P_f

$$\langle -\ln(P_i) \rangle = -\langle \ln(P_i) \rangle = -\left(\frac{1}{2} \ln(1/2) + \frac{1}{2} \ln(1/2) \right) = \ln(2), \quad (2.24)$$

$$\langle \ln(P_f) \rangle = \ln(1) + \lim_{p \rightarrow 0} p \ln(p) = 0, \quad (2.25)$$

and also note that the heat released into the reservoir is equal to the difference in energy due to the interaction

$$Q = E_m - E_n \quad (2.26)$$

This way, we obtain:

$$\ln(2) \leq \langle \beta Q \rangle, \quad (2.27)$$

which leads us to:

$$k_B T \ln(2) \leq \langle Q \rangle \quad (2.28)$$

Finally, using $W = \Delta E_{\text{Heat}} + \Delta E_{\text{Sys}}$ and considering that the atom is degenerated in energy, we have $W = Q$ (recall that Q is the heat dissipated into the reservoir):

$$k_B T \ln(2) \leq \langle W \rangle, \quad (2.29)$$

where W is the external work applied (and $\langle W \rangle$ its expected value).

2.4 Parametric Down-Conversion

In the present work, we will address a specific setup whose central role is played by a nonlinear process. We are referring to spontaneous parametric down-conversion (SPDC), which occurs in some birefringent crystals where high energy pump photons are converted into pairs of low energy signal and idler photons [17], commonly referred to as “twins”.

Normally, the pump beam must be horizontally polarized (with respect to the crystal) to be able to generate SPDC. On the other hand, it does not necessarily have to be of high intensity in order for SPDC to occur, although it does make the effect more notorious.

“Parametric” means that the process does not change the crystal [17]. Thus, energy and momentum of the *destroyed* photon must equal the total energy and momentum of the created *photons*. There are also correlations in polarization: type I crystals create photons with the same polarization; type II crystals create photons with perpendicular polarization. In general the twins are highly entangled.

An useful feature of SPDC is that the pump beam can be a coherent laser, and the twin photons will still be strongly-entangled single photons, which is useful for fundamental tests of quantum mechanics.

Twins are not necessarily created with the same energy, but we will post-select twins created in paths symmetrical to the pump beam path, so that they have the same frequency. Also, we will be using type-I crystals in the following sections.

In this thesis, we propose the use of BBO (β -barium borate) nonlinear crystals not only for SPDC, but also for the inverse process, where twin photons are destroyed and a higher-energy photon is created on the pump beam. We will use this on a special kind of second-order interferometer [18] that will serve as a simulation of a deletion process.

Chapter 3

Simulation

“Both simulators and computers are physical devices that reveal information about a mathematical function.(...) If the function is interpreted as part of a physical model then we are likely to call the device a simulator. (...) a simulation is usually the first step in a two-step process, with the second being the comparison of the physical model with a real physical system.” (Johnson, [19])

Simulation can be done not only on physical processes, but also on processes forbidden by the laws of physics. A physical system can -through a function- map a process that is not physical. For instance, conjugation of a qubit (unphysical process) can be simulated by mapping a 2-qubit system into a single qubit through a function, something called an *embedding* quantum simulation [20].

Some unphysical simulations can even find application in real-world physical phenomena. The qubit-conjugation simulation, for example, allows to make theoretical predictions for the Majorana equation, which -along with the Dirac equation- is considered a possible model for neutrinos [20].

We will be interested in the simulation of a quantum deletion process, but not with any kind of simulation. Through our simulation, we will actually realize a coherent erasure process which will be effectively irreversible.

We will start by making a model for deletion.

3.1 Modelling a Deleter

To adequately model a quantum deletion, which is an unphysical process, special care must be taken to avoid generating more unphysicalities than necessary. We want to avoid losing normalization of the input states, as this can lead to states for which quantum mechanics has no clear interpretation. Moreover, even the single-

valuedness of the evolution can be lost, leading to mathematical ambiguities.

A reasonable formulation of a deleter for a single qubit is to project an arbitrary state $|\psi\rangle$ into a constant state $|c\rangle$. This is usually done against a copy [6] [7] [3], presumably to make deletion the inverse of cloning, but we do not find any advantage in such a thing. Thus, we will dispense with the copy, but want to first know whether this choice generates a different kind of unphysicality. We will be more specific on the matter:

Let A and B be arbitrary unphysical phenomena (*unphysicalities*). The laws broken by A will be all the physical laws that can be proved to be broken by a single use of A in an otherwise physical setup. We will deem A to be *stronger* than B (and B *weaker* than A) if A breaks all the laws B breaks, but B does not break all the laws A breaks. Using this criteria, not all phenomena will be comparable, but it will be useful for similar unphysicalities. The weaker the unphysicality is, the closer it is to being physical.

The possibility of *deleting* implies that *deleting against a copy* is possible. The inverse is not true, so *deleting against a copy* can not be a stronger unphysicality than simply *deleting* (because one is implied by the other). It is not necessarily weaker, either, but *deleting against a copy* is guaranteed to not-be stronger than simply *deleting*. *Deleting against two copies* is guaranteed to not-be stronger than any of the two other choices, and so on. This way, we have defined a “family” of unphysicalities, all of which can be implied by the *Deletion* unphysicality. If we chose *Deletion against a copy*, we may get a weaker unphysicality, albeit not simpler, and certainly not the best unphysicality to represent the family. We will thus choose the simplest option, and consider deletion without the need of a copy:

$$|\psi\rangle \rightarrow |c\rangle, \tag{3.1}$$

where $|\psi\rangle$ stands for any unentangled state.

Our model has not yet stated what happens if we apply deletion on one member (qubit) of an entangled state. A simple solution is to assume that this evolution behaves linearly. If we simply do so, however, we will break the single-valuedness of the evolution in some cases. As a proof, let $|\psi\rangle$ be the following entangled state:

$$|\psi\rangle = \frac{1}{\sqrt{2}}\left(|+\rangle|+\rangle + |-\rangle|-\rangle\right), \tag{3.2}$$

where $|+\rangle = \frac{1}{\sqrt{2}}(|0\rangle + |1\rangle)$ and $|-\rangle = \frac{1}{\sqrt{2}}(|0\rangle - |1\rangle)$.

The first qubit is given to Alice, and the second to Bob. Alice then, hypothetically, applies a deletion evolution on her qubit. According to (3.1), any arbitrary

qubit is evolved into $|c\rangle$, and (assuming linearity) the output of the deletion is:

$$|\psi\rangle = \frac{1}{\sqrt{2}}\left(|c\rangle|+\rangle + |c\rangle|-\rangle\right), \quad (3.3)$$

which is equivalent to:

$$|\psi\rangle = |c\rangle|0\rangle \quad (3.4)$$

As we know, 3.2 can also be written in the following form:

$$|\psi\rangle = \frac{1}{2}\left(\left(|0\rangle + |1\rangle\right)|+\rangle + \left(|0\rangle - |1\rangle\right)|-\rangle\right) \quad (3.5)$$

and, if our deletion evolution is linear, it maps $|0\rangle$ and $|1\rangle$ in the first qubit into $|c\rangle$:

$$|\psi\rangle = \frac{1}{2}\left(\left(|c\rangle + |c\rangle\right)|+\rangle + \left(|c\rangle - |c\rangle\right)|-\rangle\right) \quad (3.6)$$

Thus, we have that the output is:

$$|\psi\rangle = |c\rangle|+\rangle, \quad (3.7)$$

which directly contradicts the result obtained in 3.4. We have shown that if we just assume linearity of 3.1, the evolution loses single-valuedness.

We will propose an extended model to avoid the loss of single-valuedness in a systematic way, while also allowing deletion evolutions on entangled states, by extending our model with the advantages of linearity, albeit with some considerations.

Thus, we will make a second model, that will serve as extension of the first, where we choose a preferred basis, and write (3.1) only for the states of that basis (we chose the canonical basis):

$$\begin{aligned} |0\rangle &\rightarrow |c\rangle \\ |1\rangle &\rightarrow |c\rangle \end{aligned} \quad (3.8)$$

This expression will be assumed linear unless normalization is broken due to the evolution. This allows for the systematic preservation of single-valuedness. As we note, the same can not be said about normalization: we only study cases where it is preserved, but our criteria for that are not systematic.

This way, we will use both (3.1) and (3.8). The first one is not linear, and is used for all pure states; the second one is linear, and can be used for some pure and entangled states, as long as the output is normalized. On the cases when both expressions can be used, they output the same result. This way, our extended

deleter-model works for all unentangled input states and some entangled states. Predictions for any other kind of states will not be part of the model.

In the path degree of freedom of a single qubit, our Deleter model would look like a “path-merger” Beam-Splitter, a device in which the output is always a specific path (we choose $|c\rangle = |0\rangle$ for simplicity; see figure 3.1).

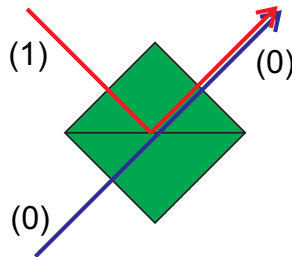

Figure 3.1: For all input states considered by the model, which includes all unentangled states and some entangled states, the output is always path (0). Predictions where normalization would be lost are intentionally avoided by the model.

3.2 Modelling a BBO

Most setups that use a BBO do not require a complete model for it, since they need only consider spontaneous parametric down-conversion. Our setup, on the other hand, requires to also consider the inverse process, where photons are destroyed in the single photon paths and created back in the *pump beam*.

SPDC and inverse SPDC occur with the same amplitude of probability. However, for the latter to happen, two single-photons must meet each other inside of the BBO at the same time. That is sufficient reason to neglect the process in most cases. In our setup, we will align the paths of the single photons created in one BBO into a second BBO, making this process important.

We propose the following Hamiltonian for the BBO:

$$H = g'(ab^\dagger c^\dagger + a^\dagger bc), \quad (3.9)$$

where the operators a and a^\dagger are destruction and creation (respectively) for the pump beam, b and b^\dagger for single photons in path (1), and c and c^\dagger for single photons in path (2) (see figure 3.2). Also, g' is a constant dependent only on the material of the BBO.

Single photons in paths (1) and (2) are always created and destroyed in vertical polarization, while a photon in the pump beam is always created or destroyed in horizontal polarization.

Solving the Schrödinger equation ($H|\psi\rangle = i\hbar\frac{\partial|\psi\rangle}{\partial t}$), we calculate the evolution $e^{-\frac{i}{\hbar}Ht}$ up to second order in $g = -\frac{g't}{\hbar}$:

$$U = \mathbb{1} + ig(ab^\dagger c^\dagger + a^\dagger bc) - \frac{g^2}{2} \left((ab^\dagger c^\dagger)^2 + (a^\dagger bc)^2 + aa^\dagger b^\dagger b c^\dagger c + a^\dagger a bb^\dagger cc^\dagger \right) \quad (3.10)$$

The g we have defined depends only on the material of the BBO, the wavelength of the pump laser and the interaction time. The material determines g' , and \hbar is a universal constant. The time t , on the other hand, is a little bit trickier: we may be tempted to say that t is the time it takes for a given wavelength of light (the pump wavelength) to traverse the size of the BBO, but it is not so. In our setup, we are assuming a given path for each one of the photons created, so t is actually the time it takes for the pump wavelength to traverse a distance equal to the single photons' coherence length (photons that have double the wavelength of the pump laser), so that they can be created on exactly the chosen paths. The coherence length of single photons is very small, and the speed of light very high, so t is very small and we can easily neglect g on higher orders.

Also, we can assume g to be real without loss of generality, because its argument is but a global phase in the setup.

We want to approximate up to second order on g , but on probability, not probability amplitude. For that matter, we can neglect the terms with double creation and double destruction of a mode, as they will be related to terms of fourth order on g .

This way, our BBO evolution is now:

$$U = \mathbb{1} + ig(ab^\dagger c^\dagger + a^\dagger bc) - \frac{g^2}{2} (aa^\dagger b^\dagger b c^\dagger c + a^\dagger a bb^\dagger cc^\dagger) \quad (3.11)$$

We will consider this as model for a BBO evolution in the sections to come.

3.3 Simulating a Deleter without postselection

A polarization-deleter can be simulated trivially by means of postselection of an unknown polarization state after a polarizing-beam-splitter (PBS). That basically means to send the state through the PBS and ignore (dump) one of the output paths. We are not interested in these kind of trivial postselection-simulations.

Instead, to simulate a quantum deletion, we are interested in “hiding” information with a process that will not allow it to be retrieved easily. The process we will show hides information so well that the system in which it is hidden is normally considered parametric (invariant) during the evolution. Also, we will not require a

classical channel of postselection for that matter.

We are referring to SPDC, in which the pump beam is normally considered parametric. The following experiment is no longer a thought experiment, but instead a fully realizable linear optics setup, based on previous setups that exploit second-order interference using two BBOs [18] [21] [22] [23].

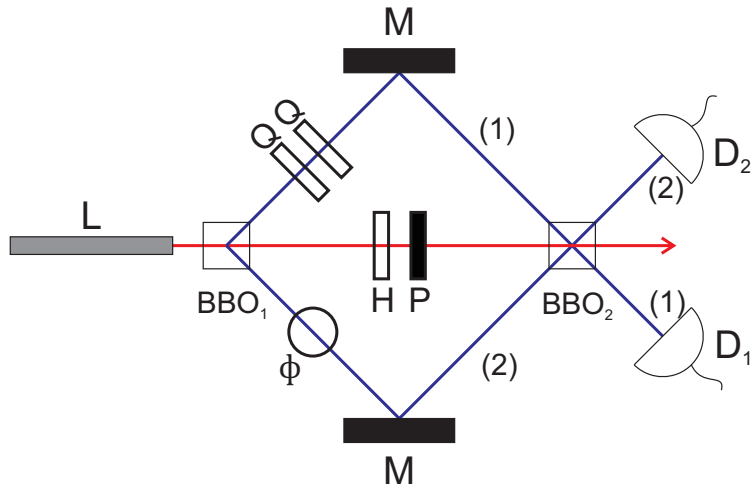

Figure 3.2: A coherent laser pump traverses two type-1 β -barium-borate crystals (BBO), which, with probability amplitude g , emit pairs of single photons with polarization $|V\rangle$. The paths of the photons emitted by BBO_1 are aligned so that they match with the paths that BBO_2 emissions would follow. “Q” and “H” are quarter and half wave plates, respectively. ϕ is a retarder, P a horizontal polarizer, M are mirrors, and D_1 and D_2 are detectors.

Two BBOs are pumped with the same coherent laser. The setup is aligned in such a way that when D_1 and D_2 detect a pair of photons, it is indistinguishable whether BBO_1 or BBO_2 made the emission, and the uncertainty of the time of emission is big enough to allow interference between the two possibilities.

Also, in a noiseless media, it is unnecessary to record coincidences between D_1 and D_2 , as single counts in one detector are sufficient to notice the interference.

The constructiveness or destructiveness of the interference can be controlled with the ϕ retarder, and its visibility can be controlled by rotating the polarization of one of the photons with the two quarter-wave plates (QWP), as that would make it partially distinguishable from emissions in BBO_2 (which are in vertical polarization). It is worth noting that two QWP are enough to produce any polarization state from a given input (without control over its global phase) [24].

We will prepare a transformation that will change the polarization state of any BBO_1 photon that goes through path (1) into a state $|\psi\rangle$ of our choice, using the two QWP. We also set the HWP (half-wave plate) so that the polarization of the

coherent laser is rotated into the linear-polarization projection of $\hat{X}|\psi\rangle$, where \hat{X} is the (flip) Pauli operator. This polarization is then projected back into horizontal by the polarizer (which is set to horizontal polarization), so the only change in the coherent laser is intensity. Finally, we set the retarder so that the state in which BBO_1 photons reach BBO_2 has phase π with respect to the coherent laser.

This way, if there were no BBO_2 , any photon coming from path (1) would reach the detector D_1 with polarization $|\psi\rangle$. However, here we add BBO_2 , making a parametric evolution on the state, so that the studied system is still approximately closed. After BBO_2 , we should not be able to reconstruct the state $|\psi\rangle$ encoded through ordinary means. The action of BBO_2 will thus be considered a simulation of a deleter-device.

Now we will make the calculations for the setup step by step:

Before the coherent laser $|\alpha\rangle$ enters the first BBO, it is horizontally polarized and there are no photons on path (1) or path (2). We will write this as $|\alpha\rangle_{0H}|0\rangle_{0V}|0\rangle_{1H}|0\rangle_{1V}|0\rangle_{2H}|0\rangle_{2V}$. The pump laser path is designated with the number tag 0, and the single photon paths are designated with 1 and 2; also, H and V designate horizontal or vertical polarization (e.g, $|2\rangle_{1V}$ designates two vertically polarized photons on path 1).

Each term in evolution U (made by the first BBO) maps the initial state $|\alpha\rangle_{0H}|0\rangle_{0V}|0\rangle_{1H}|0\rangle_{1V}|0\rangle_{2H}|0\rangle_{2V}$ in the following way:

$$\begin{aligned}
& |\alpha\rangle_{0H}|0\rangle_{0V}|0\rangle_{1H}|0\rangle_{1V}|0\rangle_{2H}|0\rangle_{2V} \\
& \xrightarrow{\mathbb{1}} |\alpha\rangle_{0H}|0\rangle_{0V}|0\rangle_{1H}|0\rangle_{1V}|0\rangle_{2H}|0\rangle_{2V} \\
& \xrightarrow{igab^\dagger c^\dagger} ig\alpha|\alpha\rangle_{0H}|0\rangle_{0V}|0\rangle_{1H}|1\rangle_{1V}|0\rangle_{2H}|1\rangle_{2V} \\
& \xrightarrow{iga^\dagger bc} 0 \\
& \xrightarrow{-\frac{g^2}{2}aa^\dagger b^\dagger b c^\dagger c} 0 \\
& \xrightarrow{-\frac{g^2}{2}a^\dagger a bb^\dagger cc^\dagger} -\frac{g^2|\alpha|^2}{2}(|\alpha\rangle + |\phi_\alpha\rangle)|0\rangle|0\rangle_{1H}|0\rangle_{1V}|0\rangle_{2H}|0\rangle_{2V}
\end{aligned} \tag{3.12}$$

Before continuing, some relations have to be remarked regarding $|\alpha\rangle$ and $|\phi_\alpha\rangle$. Let's first recall that:

$$|\alpha\rangle = e^{-\frac{|\alpha|^2}{2}} \sum_{n=0}^{\infty} \frac{\alpha^n}{\sqrt{n!}} |n\rangle \tag{3.13}$$

Now, for $|\alpha| \gg 0$, $a^\dagger a$ applied on $|\alpha\rangle$ is approximately $|\alpha|^2|\alpha\rangle$, but we will not assume $|\alpha| \gg 0$. Instead, on 3.12 we are using the exact value:

$$a^\dagger a |\alpha\rangle = e^{-\frac{|\alpha|^2}{2}} \sum_{n=0}^{\infty} \frac{\alpha^n}{\sqrt{n!}} n |n\rangle, \quad (3.14)$$

which can be separated into two terms like this:

$$a^\dagger a |\alpha\rangle = |\alpha|^2 |\alpha\rangle + |\alpha|^2 |\phi_\alpha\rangle, \quad (3.15)$$

such that $|\phi_\alpha\rangle$ is defined as:

$$|\phi_\alpha\rangle = \frac{a^\dagger a |\alpha\rangle}{|\alpha|^2} - |\alpha\rangle = \frac{1}{|\alpha|^2} e^{-\frac{|\alpha|^2}{2}} \sum_{n=0}^{\infty} \frac{\alpha^n}{\sqrt{n!}} (n - |\alpha|^2) |n\rangle \quad (3.16)$$

Now, we will show that $|\phi_\alpha\rangle$ is orthogonal to $|\alpha\rangle$. For that, the following scalar should be 0:

$$\langle \alpha | \phi_\alpha \rangle = \frac{\langle \alpha | a^\dagger a |\alpha\rangle}{|\alpha|^2} - \langle \alpha | \alpha \rangle \quad (3.17)$$

We know that $a |\alpha\rangle = \alpha |\alpha\rangle$ and thus $\langle \alpha | a^\dagger = \langle \alpha | \alpha^*$:

$$\langle \alpha | \phi_\alpha \rangle = \frac{\langle \alpha | \alpha^* \alpha |\alpha\rangle}{|\alpha|^2} - \langle \alpha | \alpha \rangle = \frac{|\alpha|^2}{|\alpha|^2} \langle \alpha | \alpha \rangle - \langle \alpha | \alpha \rangle = 0 \quad (3.18)$$

Thus, we see that $|\phi_\alpha\rangle$ is orthogonal to $|\alpha\rangle$, for any arbitrary coherent state $|\alpha\rangle$. This will be useful in a moment.

The total output after the first BBO is:

$$\begin{aligned} |\alpha\rangle_{0H} |0\rangle_{0V} \left(\left(1 - \frac{g^2 |\alpha|^2}{2}\right) |0\rangle_{1H} |0\rangle_{1V} |0\rangle_{2H} |0\rangle_{2V} + ig\alpha |0\rangle_{1H} |1\rangle_{1V} |0\rangle_{2H} |1\rangle_{2V} \right) \\ + \frac{g^2 |\alpha|^2}{2} |\phi_\alpha\rangle |0\rangle_{1H} |0\rangle_{1V} |0\rangle_{2H} |0\rangle_{2V} \quad (3.19) \end{aligned}$$

We are interested in approximating up to order g^3 on probability (not amplitude). Since we have proven that $|\phi_\alpha\rangle$ is orthogonal to $|\alpha\rangle$, the last term in 3.19 is of order g^4 on probability, so it is eliminated (if they were not orthogonal, $|\phi_\alpha\rangle$ would have a contribution of order g^2 on $|\alpha\rangle_{0H} |0\rangle_{0V} |0\rangle_{1H} |0\rangle_{1V} |0\rangle_{2H} |0\rangle_{2V}$).

We do not eliminate the $\frac{g^2 |\alpha|^2}{2}$ in the amplitude of $|\alpha\rangle_{0H} |0\rangle_{0V} |0\rangle_{1H} |0\rangle_{1V} |0\rangle_{2H} |0\rangle_{2V}$, because it still contributes in order g^2 (to the probability) when squaring the complete amplitude.

This way, the state after the first BBO, up to order g^3 on probability, is:

$$|\alpha\rangle_{0H} |0\rangle_{0V} \left(\left(1 - \frac{g^2 |\alpha|^2}{2}\right) |0\rangle_{1H} |0\rangle_{1V} |0\rangle_{2H} |0\rangle_{2V} + ig\alpha |0\rangle_{1H} |1\rangle_{1V} |0\rangle_{2H} |1\rangle_{2V} \right) \quad (3.20)$$

Then, we rotate the photon on path (1) with vertical polarization into $|\psi\rangle_1 = a|1\rangle_{1H}|0\rangle_{1V} + b|0\rangle_{1H}|1\rangle_{1V}$, using the two QWP. We choose b to be real without loss of generality (this can be controlled with the retarder later on):

$$|\alpha\rangle_{0H}|0\rangle_{0V} \left(\left(1 - \frac{g^2|\alpha|^2}{2}\right) |0\rangle_{1H}|0\rangle_{1V}|0\rangle_{2H}|0\rangle_{2V} + ig\alpha(a|1\rangle_{1H}|0\rangle_{1V}|0\rangle_{2H}|1\rangle_{2V} + b|0\rangle_{1H}|1\rangle_{1V}|0\rangle_{2H}|1\rangle_{2V}) \right) \quad (3.21)$$

Then, the coherent laser is changed into $|b\alpha\rangle_{0H}|0\rangle_{0V}$ by means of the H waveplate and polarizer (note that we have partially included the information of $|\psi\rangle$ here, through the real parameter b). Also, the retarder sets the phase of the single photons to be π (additional to the phase of i), and compensates the necessary phase for b to be real (a is still complex):

$$|b\alpha\rangle_{0H}|0\rangle_{0V} \left(\left(1 - \frac{g^2|\alpha|^2}{2}\right) |0\rangle_{1H}|0\rangle_{1V}|0\rangle_{2H}|0\rangle_{2V} + ig\alpha e^{i\pi}(a|1\rangle_{1H}|0\rangle_{1V}|0\rangle_{2H}|1\rangle_{2V} + b|0\rangle_{1H}|1\rangle_{1V}|0\rangle_{2H}|1\rangle_{2V}) \right) \quad (3.22)$$

If there were no BBO_2 , we would obtain $|\psi\rangle$ when measuring the polarization of photons coming from path (1) (that is, if we postselect 3.22 for cases in which there is a photon in path (1), those photons would have polarization $|\psi\rangle$). However, we will now consider the BBO_2 transformation.

The state $|b\alpha\rangle_{0H}|0\rangle_{0V}|1\rangle_{1H}|0\rangle_{1V}|0\rangle_{2H}|1\rangle_{2V}$ is mapped by the terms of U in an analogous way to how $|\alpha\rangle_{0H}|0\rangle_{0V}|0\rangle_{1H}|0\rangle_{1V}|0\rangle_{2H}|0\rangle_{2V}$ transformed in 3.12 (note that $|\phi_{b\alpha}\rangle$ is the same state defined before):

$$\begin{aligned} & |b\alpha\rangle_{0H}|0\rangle_{0V}|1\rangle_{1H}|0\rangle_{1V}|0\rangle_{2H}|1\rangle_{2V} \\ & \xrightarrow{\mathbb{1}} |b\alpha\rangle_{0H}|0\rangle_{0V}|1\rangle_{1H}|0\rangle_{1V}|0\rangle_{2H}|1\rangle_{2V} \\ & \xrightarrow{igab^\dagger c^\dagger} \sqrt{2}ibg\alpha|b\alpha\rangle_{0H}|0\rangle_{0V}|1\rangle_{1H}|1\rangle_{1V}|0\rangle_{2H}|2\rangle_{2V} \\ & \xrightarrow{iga^\dagger bc} 0 \\ & \xrightarrow{-\frac{g^2}{2}aa^\dagger b^\dagger b c^\dagger c} 0 \\ & \xrightarrow{-\frac{g^2}{2}a^\dagger a bb^\dagger cc^\dagger} -b^2g^2|\alpha|^2 \left(|b\alpha\rangle + |\phi_{b\alpha}\rangle \right) |0\rangle|1\rangle_{1H}|0\rangle_{1V}|0\rangle_{2H}|1\rangle_{2V} \end{aligned} \quad (3.23)$$

On the other hand, $|b\alpha\rangle_{0H}|0\rangle_{0V}|0\rangle_{1H}|1\rangle_{1V}|0\rangle_{2H}|1\rangle_{2V}$ is mapped differently, since it can produce inverse SPDC. Each of the terms of U maps it the following way:

$$\begin{aligned}
& |b\alpha\rangle_{0H}|0\rangle_{0V}|0\rangle_{1H}|1\rangle_{1V}|0\rangle_{2H}|1\rangle_{2V} \\
& \xrightarrow{\mathbb{1}} |b\alpha\rangle_{0H}|0\rangle_{0V}|0\rangle_{1H}|1\rangle_{1V}|0\rangle_{2H}|1\rangle_{2V} \\
& \xrightarrow{igab^\dagger c^\dagger} igb\alpha|b\alpha\rangle_{0H}|0\rangle_{0V}|0\rangle_{1H}|2\rangle_{1V}|0\rangle_{2H}|2\rangle_{2V} \\
& \xrightarrow{iga^\dagger bc} igb^*\alpha^*\left(|b\alpha\rangle + |\phi_{b\alpha}\rangle\right)|0\rangle|0\rangle_{1H}|0\rangle_{1V}|0\rangle_{2H}|0\rangle_{2V} \\
& \xrightarrow{-\frac{g^2}{2}aa^\dagger b^\dagger b c^\dagger c} -\frac{g^2}{2}\left(\left(1 - b^2|\alpha|^2\right)|b\alpha\rangle - b^2|\alpha|^2|\phi_{b\alpha}\rangle\right)|0\rangle|0\rangle_{1H}|1\rangle_{1V}|0\rangle_{2H}|1\rangle_{2V} \\
& \xrightarrow{-\frac{g^2}{2}a^\dagger a bb^\dagger cc^\dagger} -2b^2g^2|\alpha|^2\left(|b\alpha\rangle + |\phi_{b\alpha}\rangle\right)|0\rangle|0\rangle_{1H}|1\rangle_{1V}|0\rangle_{2H}|1\rangle_{2V}
\end{aligned} \tag{3.24}$$

To obtain this, we have used 3.15, and considered that coherent states are eigenvectors of a ($a|\alpha\rangle = \alpha|\alpha\rangle$), so as to note that $a^\dagger|\alpha\rangle = \alpha^*(|\alpha\rangle + |\phi_\alpha\rangle)$.

Also, to obtain $aa^\dagger|\alpha\rangle$, we have used the commutation relation $[a, a^\dagger] = \mathbb{1}$ and written $aa^\dagger = \mathbb{1} - a^\dagger a$. The result was:

$$aa^\dagger|\alpha\rangle = (\mathbb{1} - a^\dagger a)|\alpha\rangle = (1 - |\alpha|^2)|\alpha\rangle - |\alpha|^2|\phi_\alpha\rangle \tag{3.25}$$

Each term of 3.22 is, thus, mapped in the following way:

$$\begin{aligned}
& |b\alpha\rangle_{0H}|0\rangle_{0V}|0\rangle_{1H}|0\rangle_{1V}|0\rangle_{2H}|0\rangle_{2V} \xrightarrow{U} \\
& \left(1 - \frac{b^2g^2|\alpha|^2}{2}\right)|b\alpha\rangle_{0H}|0\rangle_{0V}|0\rangle_{1H}|0\rangle_{1V}|0\rangle_{2H}|0\rangle_{2V} + ibg\alpha|b\alpha\rangle_{0H}|0\rangle_{0V}|0\rangle_{1H}|1\rangle_{1V}|0\rangle_{2H}|1\rangle_{2V} \\
& \quad - \frac{b^2g^2|\alpha|^2}{2}|\phi_{b\alpha}\rangle|0\rangle|0\rangle_{1H}|0\rangle_{1V}|0\rangle_{2H}|0\rangle_{2V} \tag{3.26}
\end{aligned}$$

$$\begin{aligned}
& |b\alpha\rangle_{0H}|0\rangle_{0V}|1\rangle_{1H}|0\rangle_{1V}|0\rangle_{2H}|1\rangle_{2V} \xrightarrow{U} \\
& |b\alpha\rangle_{0H}|0\rangle_{0V}\left(\left(1 - b^2g^2|\alpha|^2\right)|1\rangle_{1H}|0\rangle_{1V}|0\rangle_{2H}|1\rangle_{2V} + \sqrt{2}ibg\alpha|1\rangle_{1H}|1\rangle_{1V}|0\rangle_{2H}|2\rangle_{2V}\right) \\
& \quad - b^2g^2|\alpha|^2|\phi_{b\alpha}\rangle|0\rangle|1\rangle_{1H}|0\rangle_{1V}|0\rangle_{2H}|1\rangle_{2V} \tag{3.27}
\end{aligned}$$

$$\begin{aligned}
& |b\alpha\rangle_{0H}|0\rangle_{0V}|0\rangle_{1H}|1\rangle_{1V}|0\rangle_{2H}|1\rangle_{2V} \xrightarrow{U} \\
& \left(1 - \frac{g^2}{2}\left(1 - b^2|\alpha|^2\right) - 2b^2g^2|\alpha|^2\right)|b\alpha\rangle_{0H}|0\rangle_{0V}|0\rangle_{1H}|1\rangle_{1V}|0\rangle_{2H}|1\rangle_{2V} \\
& + igb\alpha|b\alpha\rangle_{0H}|0\rangle_{0V}|0\rangle_{1H}|2\rangle_{1V}|0\rangle_{2H}|2\rangle_{2V} + igb^*\alpha^*|b\alpha\rangle_{0H}|0\rangle_{0V}|0\rangle_{1H}|0\rangle_{1V}|0\rangle_{2H}|0\rangle_{2V} \\
& \quad + igb^*\alpha^*|\phi_{b\alpha}\rangle|0\rangle|0\rangle_{1H}|0\rangle_{1V}|0\rangle_{2H}|0\rangle_{2V} \\
& \quad + \left(\frac{g^2}{2}b^2|\alpha|^2 - 2b^2g^2|\alpha|^2\right)|\phi_{b\alpha}\rangle|0\rangle|0\rangle_{1H}|1\rangle_{1V}|0\rangle_{2H}|1\rangle_{2V} \tag{3.28}
\end{aligned}$$

Before continuing, we can notice that -in the total output- all terms with $|\phi_{b\alpha}\rangle$ make contributions of order g^4 or higher (g^5 or g^6) in probability. To conclude that, we have considered the amplitude of each term in 3.22 (and the fact that $|\phi_{b\alpha}\rangle$ is orthogonal to $|b\alpha\rangle$). This way, we can neglect these terms to simplify calculations.

$$\begin{aligned}
& |\mathbf{b}\alpha\rangle_{0\mathbf{H}}|\mathbf{0}\rangle_{0\mathbf{V}}|\mathbf{0}\rangle_{1\mathbf{H}}|\mathbf{0}\rangle_{1\mathbf{V}}|\mathbf{0}\rangle_{2\mathbf{H}}|\mathbf{0}\rangle_{2\mathbf{V}} \xrightarrow{U} \\
& |\mathbf{b}\alpha\rangle_{0\mathbf{H}}|\mathbf{0}\rangle_{0\mathbf{V}} \left(\left(1 - \frac{b^2 g^2 |\alpha|^2}{2}\right) |0\rangle_{1\mathbf{H}}|0\rangle_{1\mathbf{V}}|0\rangle_{2\mathbf{H}}|0\rangle_{2\mathbf{V}} + ibg\alpha |0\rangle_{1\mathbf{H}}|1\rangle_{1\mathbf{V}}|0\rangle_{2\mathbf{H}}|1\rangle_{2\mathbf{V}} \right)
\end{aligned} \tag{3.29}$$

$$\begin{aligned}
& |\mathbf{b}\alpha\rangle_{0\mathbf{H}}|\mathbf{0}\rangle_{0\mathbf{V}}|\mathbf{1}\rangle_{1\mathbf{H}}|\mathbf{0}\rangle_{1\mathbf{V}}|\mathbf{0}\rangle_{2\mathbf{H}}|\mathbf{1}\rangle_{2\mathbf{V}} \xrightarrow{U} \\
& |\mathbf{b}\alpha\rangle_{0\mathbf{H}}|\mathbf{0}\rangle_{0\mathbf{V}} \left(\left(1 - b^2 g^2 |\alpha|^2\right) |1\rangle_{1\mathbf{H}}|0\rangle_{1\mathbf{V}}|0\rangle_{2\mathbf{H}}|1\rangle_{2\mathbf{V}} + \sqrt{2}ibg\alpha |1\rangle_{1\mathbf{H}}|1\rangle_{1\mathbf{V}}|0\rangle_{2\mathbf{H}}|2\rangle_{2\mathbf{V}} \right)
\end{aligned} \tag{3.30}$$

$$\begin{aligned}
& |\mathbf{b}\alpha\rangle_{0\mathbf{H}}|\mathbf{0}\rangle_{0\mathbf{V}}|\mathbf{0}\rangle_{1\mathbf{H}}|\mathbf{1}\rangle_{1\mathbf{V}}|\mathbf{0}\rangle_{2\mathbf{H}}|\mathbf{1}\rangle_{2\mathbf{V}} \xrightarrow{U} \\
& |\mathbf{b}\alpha\rangle_{0\mathbf{H}}|\mathbf{0}\rangle_{0\mathbf{V}} \left(\left(1 - \frac{g^2}{2}(1 + 3b^2 |\alpha|^2)\right) |0\rangle_{1\mathbf{H}}|1\rangle_{1\mathbf{V}}|0\rangle_{2\mathbf{H}}|1\rangle_{2\mathbf{V}} \right. \\
& \quad \left. + ibg\alpha |0\rangle_{1\mathbf{H}}|2\rangle_{1\mathbf{V}}|0\rangle_{2\mathbf{H}}|2\rangle_{2\mathbf{V}} + igb^* \alpha^* |0\rangle_{1\mathbf{H}}|0\rangle_{1\mathbf{V}}|0\rangle_{2\mathbf{H}}|0\rangle_{2\mathbf{V}} \right)
\end{aligned} \tag{3.31}$$

That way, we obtain the following output right after BBO_2 (we apply 3.29, 3.30 and 3.31 on 3.22):

$$\begin{aligned}
& |\mathbf{b}\alpha\rangle_{0\mathbf{H}}|\mathbf{0}\rangle_{0\mathbf{V}} \left(\left(1 - \frac{g^2 |\alpha|^2}{2}\right) \left(\left(1 - \frac{b^2 g^2 |\alpha|^2}{2}\right) |0\rangle_{1\mathbf{H}}|0\rangle_{1\mathbf{V}}|0\rangle_{2\mathbf{H}}|0\rangle_{2\mathbf{V}} \right. \right. \\
& \quad \left. \left. + ibg\alpha |0\rangle_{1\mathbf{H}}|1\rangle_{1\mathbf{V}}|0\rangle_{2\mathbf{H}}|1\rangle_{2\mathbf{V}} \right) \right. \\
& \quad \left. + iag\alpha e^{i\pi} \left(\left(1 - b^2 g^2 |\alpha|^2\right) |1\rangle_{1\mathbf{H}}|0\rangle_{1\mathbf{V}}|0\rangle_{2\mathbf{H}}|1\rangle_{2\mathbf{V}} + \sqrt{2}ibg\alpha |1\rangle_{1\mathbf{H}}|1\rangle_{1\mathbf{V}}|0\rangle_{2\mathbf{H}}|2\rangle_{2\mathbf{V}} \right) \right. \\
& \quad \left. + ibg\alpha e^{i\pi} \left(\left(1 - \frac{g^2}{2}(1 + 3b^2 |\alpha|^2)\right) |0\rangle_{1\mathbf{H}}|1\rangle_{1\mathbf{V}}|0\rangle_{2\mathbf{H}}|1\rangle_{2\mathbf{V}} \right. \right. \\
& \quad \left. \left. + ibg\alpha |0\rangle_{1\mathbf{H}}|2\rangle_{1\mathbf{V}}|0\rangle_{2\mathbf{H}}|2\rangle_{2\mathbf{V}} + igb^* \alpha^* |0\rangle_{1\mathbf{H}}|0\rangle_{1\mathbf{V}}|0\rangle_{2\mathbf{H}}|0\rangle_{2\mathbf{V}} \right) \right),
\end{aligned} \tag{3.32}$$

which is equivalent to:

$$\begin{aligned}
|b\alpha\rangle_{0H}|0\rangle_{0V} & \left(\left(1 - \frac{g^2|\alpha|^2}{2}(1-b^2) + \frac{b^2g^4|\alpha|^4}{4} \right) |0\rangle_{1H}|0\rangle_{1V}|0\rangle_{2H}|0\rangle_{2V} \right. \\
& - iag\alpha(1-b^2g^2|\alpha|^2) |1\rangle_{1H}|0\rangle_{1V}|0\rangle_{2H}|1\rangle_{2V} \\
& + ibg\alpha \left((1+e^{i\pi}) + \frac{g^2}{2}(1+3b^2|\alpha|^2) \right) |0\rangle_{1H}|1\rangle_{1V}|0\rangle_{2H}|1\rangle_{2V} \\
& \left. + \sqrt{2}abg^2\alpha^2 |1\rangle_{1H}|1\rangle_{1V}|0\rangle_{2H}|2\rangle_{2V} + b^2g^2\alpha^2 |0\rangle_{1H}|2\rangle_{1V}|0\rangle_{2H}|2\rangle_{2V} \right) \quad (3.33)
\end{aligned}$$

Let us note that the single-photon term $|0\rangle_{1H}|1\rangle_{1V}|0\rangle_{2H}|1\rangle_{2V}$ has interfered destructively up to order g^5 in probability. Now, we will retain only those terms that contribute up to order g^3 in probability:

$$|b\alpha\rangle_{0H}|0\rangle_{0V} \left(\left(1 - \frac{g^2|\alpha|^2}{2}(1-b^2) \right) |0\rangle_{1H}|0\rangle_{1V}|0\rangle_{2H}|0\rangle_{2V} - iag\alpha |1\rangle_{1H}|0\rangle_{1V}|0\rangle_{2H}|1\rangle_{2V} \right) \quad (3.34)$$

Since the $|0\rangle_{1H}|1\rangle_{1V}|0\rangle_{2H}|1\rangle_{2V}$ terms have disappeared in destructive interference, when we measure single photons (in D_1 or D_2), we will always find them on constant polarization states (path (1) on horizontal polarization and path (2) on vertical polarization). This way, for single-photon detectors, it will be as if the state $|\psi\rangle$ had been mapped to a constant state in all detections. Thus, we can consider that BBO_2 has simulated a deletion of the polarization information ($|\psi\rangle$).

It is also worth noting that the inverse SPDC is not responsible for the simulated deletion. It is simply necessary for the state to be normalized at all times. Also, depending on the value of ϕ , this setup can be used to suppress or amplify SPDC between 0 and 4 times its probability in a single BBO.

As we may have noted, the quantum information of the state $|\psi\rangle$ is actually classically encoded information, since an observer can look at the wave plates that rotate the single photon in path (1) and deduce the state into which it was rotated. Would it be possible to make this simulation with a single, unknown copy of $|\psi\rangle$? We will see this in the following section.

3.4 Simulating a Deleter for an unknown state

Let us have the same setup given in the previous section, but without any QWP. Instead, we will encode the unknown state $|\psi\rangle$ into one of the photons that passes through path (1), by use of an external state in interaction with that mode (right where the QWP were located).

To do that, we would have to do a Swap-like transformation between the states. For that, our external state will be in a 2-Fock space. Also, we will use the number tag 3 for it. We are referring to the same $|\psi\rangle$ of last section, so it will be:

$$|\psi\rangle_3 = a|1\rangle_{3H}|0\rangle_{3V} + b|0\rangle_{3H}|1\rangle_{3V}, \quad (3.35)$$

where we choose b to be real without loss of generality.

We will write the Swap-like transformation in terms of creation and destruction operators for the external state and for path-(1) photon mode. For the latter, our operators will be \hat{a}_H and \hat{a}_H^\dagger (creation and destruction, respectively) for horizontally polarized photons, and \hat{a}_V and \hat{a}_V^\dagger for vertically polarized photons. For the external 2-Fock state, our operators are \hat{c}_H and \hat{c}_H^\dagger for the first Fock state and \hat{c}_V and \hat{c}_V^\dagger for the second (we are using the tags ‘‘H’’ and ‘‘V’’ for convenience, even though the system is not necessarily made of photons).

We submit our *external* and path-(1) Fock states to hamiltonian H_2 (for the purposes of our analysis, it is not important how to implement this Hamiltonian, as this will be a thought experiment):

$$H_2 = -\kappa' \left(\hat{a}_H^\dagger \hat{a}_H \hat{c}_H^\dagger \hat{c}_H + \hat{a}_V^\dagger \hat{a}_V \hat{c}_V^\dagger \hat{c}_V + \hat{a}_H^\dagger \hat{a}_V \hat{c}_V^\dagger \hat{c}_H + \hat{a}_V^\dagger \hat{a}_H \hat{c}_H^\dagger \hat{c}_V \right) = -\kappa' M \quad (3.36)$$

This Hamiltonian will act only on photons within a localized part of path-(1). For that matter, we choose the creation and destruction operators a and a^\dagger to act on a specific location of path (1), right after the first BBO.

This way, the highest probability amplitude at a given time is for the photonic state $|0\rangle_{1H}|0\rangle_{1V}$ to be within the location where our operators a and a^\dagger act. For that state, the system is invariant (under Hamiltonian H_2).

There is a low probability amplitude that at a given time a single photon is within the localized area of the Hamiltonian. Such a photon would stay during time t , which is of the order of the decoherence length of the single photon (which is very small) divided by the speed of light in that medium (which is very high). This way, if we consider κ' to be a real constant, and define $\kappa = \frac{\kappa' t}{\hbar}$, we note that κ is a small real constant for single photon states (and also for higher Fock states).

The evolution is unitary. Indeed, $M = \hat{a}_H^\dagger \hat{a}_H \hat{c}_H^\dagger \hat{c}_H + \hat{a}_V^\dagger \hat{a}_V \hat{c}_V^\dagger \hat{c}_V + \hat{a}_H^\dagger \hat{a}_V \hat{c}_V^\dagger \hat{c}_H + \hat{a}_V^\dagger \hat{a}_H \hat{c}_H^\dagger \hat{c}_V = M^\dagger$ and, as κ is real, the evolution $V = e^{i\kappa M}$ is unitary.

We will now show the Swap-like property of our evolution. Let us approximate V up to second order in κ :

$$V = \mathbb{1} + i\kappa M - \frac{\kappa^2}{2} M^2 + O(\kappa^3) \quad (3.37)$$

Also, let $|\phi_1\rangle_1$ and $|\phi_3\rangle_3$ be arbitrary qubits spanned from $\{|1\rangle_{1H}|0\rangle_{1V}, |0\rangle_{1H}|1\rangle_{1V}\}$ and from $\{|1\rangle_{3H}|0\rangle_{3V}, |0\rangle_{3H}|1\rangle_{3V}\}$, respectively.

We can trivially show that they transform under V as follows (up to second order in κ):

$$|\phi_1\rangle_1|\phi_3\rangle_3 \xrightarrow{V} \left(1 - \frac{\kappa^2}{2}\right)|\phi_1\rangle_1|\phi_3\rangle_3 + i\kappa|\phi_3\rangle_1|\phi_1\rangle_3 \quad (3.38)$$

That is, there is a probability amplitude of $i\kappa$ for a Swap between the two states.

Now let us include this result in the context of our Deletion simulation. Right after the first BBO, the total state is given by 3.20 and the external state $|\psi\rangle_3 = a|1\rangle_{3H}|0\rangle_{3V} + b|0\rangle_{3H}|1\rangle_{3V}$ (with unknown complex a and unknown real b):

$$|\alpha\rangle_{0H}|0\rangle_{0V} \left(\left(1 - \frac{g^2|\alpha|^2}{2}\right)|0\rangle_{1H}|0\rangle_{1V}|0\rangle_{2H}|0\rangle_{2V} + ig\alpha|0\rangle_{1H}|1\rangle_{1V}|0\rangle_{2H}|1\rangle_{2V} \right) |\psi\rangle_3 \quad (3.39)$$

Then comes our V interaction, in which the first term of 3.39 is invariant, while the second term transforms as given in 3.38:

$$\begin{aligned} \xrightarrow{V} |\alpha\rangle_{0H}|0\rangle_{0V} & \left(\left(1 - \frac{g^2|\alpha|^2}{2}\right)|0\rangle_{1H}|0\rangle_{1V}|0\rangle_{2H}|0\rangle_{2V} |\psi\rangle_3 \right. \\ & + ig\alpha \left(1 - \frac{\kappa^2}{2}\right) |0\rangle_{1H}|1\rangle_{1V}|0\rangle_{2H}|1\rangle_{2V} |\psi\rangle_3 \\ & \left. - g\alpha\kappa |\psi\rangle_1 |0\rangle_{2H}|1\rangle_{2V} |0\rangle_{3H}|1\rangle_{3V} \right) \quad (3.40) \end{aligned}$$

Then, we would include the retarder with $\phi = \pi$ to make the single photons emitted from BBO_1 have a relative phase of $e^{i\pi} = -1$ with respect to the ones that could be emitted from BBO_2 . In 3.40 (after compensating for path difference) $\phi = \frac{\pi}{2}$ is the phase we need instead. We include this retarder.

Also, we would rotate and project the coherent laser so as to get $|b\alpha\rangle_{0H}|0\rangle_{0V}$. This time, we will rotate and project it to obtain $|\kappa\alpha\rangle_{0H}|0\rangle_{0V}$ instead. Note that we are not required to know b this time (we did need to know it in the previous section).

After these two changes, we have:

$$\begin{aligned} |\kappa\alpha\rangle_{0H}|0\rangle_{0V} & \left(\left(1 - \frac{g^2|\alpha|^2}{2}\right)|0\rangle_{1H}|0\rangle_{1V}|0\rangle_{2H}|0\rangle_{2V} |\psi\rangle_3 \right. \\ & + ie^{i\phi}g\alpha \left(1 - \frac{\kappa^2}{2}\right) |0\rangle_{1H}|1\rangle_{1V}|0\rangle_{2H}|1\rangle_{2V} |\psi\rangle_3 \\ & \left. - e^{i\phi}g\alpha\kappa |\psi\rangle_1 |0\rangle_{2H}|1\rangle_{2V} |0\rangle_{3H}|1\rangle_{3V} \right) \quad (3.41) \end{aligned}$$

This way, if there were no BBO_2 , for each single photon that we receive from path (1), there is a chance of $|\kappa|^2$ probability that we are receiving the state $|\psi\rangle_1 = a|1\rangle_{1H}|0\rangle_{1V} + b|0\rangle_{1H}|1\rangle_{1V}$, and a chance of $1 - |\kappa|^2$ that it is vertically polarized and the state $|\psi\rangle$ remains encoded in the external system. This means that after many iterations of the experiment, we would eventually receive the state $|\psi\rangle_1$.

We will now include BBO_2 , which performs evolution U on the system. This maps the terms of 3.41 in an analogous way to 3.29, 3.30 and 3.31 (we only substitute all b with κ):

$$\begin{aligned}
& |\kappa\alpha\rangle_{0H}|\mathbf{0}\rangle_{0V}|\mathbf{0}\rangle_{1H}|\mathbf{0}\rangle_{1V}|\mathbf{0}\rangle_{2H}|\mathbf{0}\rangle_{2V} \xrightarrow{U} \\
& |\kappa\alpha\rangle_{0H}|0\rangle_{0V} \left(\left(1 - \frac{\kappa^2 g^2 |\alpha|^2}{2}\right) |0\rangle_{1H}|0\rangle_{1V}|0\rangle_{2H}|0\rangle_{2V} + i\kappa g\alpha |0\rangle_{1H}|1\rangle_{1V}|0\rangle_{2H}|1\rangle_{2V} \right)
\end{aligned} \tag{3.42}$$

$$\begin{aligned}
& |\kappa\alpha\rangle_{0H}|\mathbf{0}\rangle_{0V}|\mathbf{1}\rangle_{1H}|\mathbf{0}\rangle_{1V}|\mathbf{0}\rangle_{2H}|\mathbf{1}\rangle_{2V} \xrightarrow{U} \\
& |\kappa\alpha\rangle_{0H}|0\rangle_{0V} \left((1 - \kappa^2 g^2 |\alpha|^2) |1\rangle_{1H}|0\rangle_{1V}|0\rangle_{2H}|1\rangle_{2V} + \sqrt{2}i\kappa g\alpha |1\rangle_{1H}|1\rangle_{1V}|0\rangle_{2H}|2\rangle_{2V} \right)
\end{aligned} \tag{3.43}$$

$$\begin{aligned}
& |\kappa\alpha\rangle_{0H}|\mathbf{0}\rangle_{0V}|\mathbf{0}\rangle_{1H}|\mathbf{1}\rangle_{1V}|\mathbf{0}\rangle_{2H}|\mathbf{1}\rangle_{2V} \xrightarrow{U} \\
& |\kappa\alpha\rangle_{0H}|0\rangle_{0V} \left(\left(1 - \frac{g^2}{2}(1 + 3\kappa^2 |\alpha|^2)\right) |0\rangle_{1H}|1\rangle_{1V}|0\rangle_{2H}|1\rangle_{2V} \right. \\
& \quad \left. + i\kappa g\alpha |0\rangle_{1H}|2\rangle_{1V}|0\rangle_{2H}|2\rangle_{2V} + ig\kappa^* \alpha^* |0\rangle_{1H}|0\rangle_{1V}|0\rangle_{2H}|0\rangle_{2V} \right)
\end{aligned} \tag{3.44}$$

The output right after BBO_2 is:

$$\begin{aligned}
& |\kappa\alpha\rangle_{0H}|0\rangle_{0V} \left(\left(1 - \frac{g^2|\alpha|^2}{2}\right)\left(1 - \frac{\kappa^2 g^2|\alpha|^2}{2}\right) |0\rangle_{1H}|0\rangle_{1V}|0\rangle_{2H}|0\rangle_{2V} |\psi\rangle_3 \right. \\
& \quad + i\kappa g\alpha \left(1 - \frac{g^2|\alpha|^2}{2}\right) |0\rangle_{1H}|1\rangle_{1V}|0\rangle_{2H}|1\rangle_{2V} |\psi\rangle_3 \\
& \quad + i e^{i\phi} g\alpha \left(1 - \frac{\kappa^2}{2}\right) \left(1 - \frac{g^2}{2}(1 + 3\kappa^2|\alpha|^2)\right) |0\rangle_{1H}|1\rangle_{1V}|0\rangle_{2H}|1\rangle_{2V} |\psi\rangle_3 \\
& \quad - \kappa g^2 \alpha^2 e^{i\phi} \left(1 - \frac{\kappa^2}{2}\right) |0\rangle_{1H}|2\rangle_{1V}|0\rangle_{2H}|2\rangle_{2V} |\psi\rangle_3 \\
& \quad - g^2 \kappa^* |\alpha|^2 e^{i\phi} \left(1 - \frac{\kappa^2}{2}\right) |0\rangle_{1H}|0\rangle_{1V}|0\rangle_{2H}|0\rangle_{2V} |\psi\rangle_3 \\
& \quad - e^{i\phi} g a \alpha \kappa \left(1 - \kappa^2 g^2 |\alpha|^2\right) |1\rangle_{1H}|0\rangle_{1V}|0\rangle_{2H}|1\rangle_{2V}|0\rangle_{3H}|1\rangle_{3V} \\
& \quad - \sqrt{2} i e^{i\phi} g^2 a \kappa^2 \alpha^2 |1\rangle_{1H}|1\rangle_{1V}|0\rangle_{2H}|2\rangle_{2V}|0\rangle_{3H}|1\rangle_{3V} \\
& \quad - e^{i\phi} g b \alpha \kappa \left(1 - \frac{g^2}{2}(1 + 3\kappa^2|\alpha|^2)\right) |0\rangle_{1H}|1\rangle_{1V}|0\rangle_{2H}|1\rangle_{2V}|0\rangle_{3H}|1\rangle_{3V} \\
& \quad - i e^{i\phi} g^2 b \kappa^2 \alpha^2 |0\rangle_{1H}|2\rangle_{1V}|0\rangle_{2H}|2\rangle_{2V}|0\rangle_{3H}|1\rangle_{3V} \\
& \quad \left. - i e^{i\phi} g^2 b |\kappa|^2 |\alpha|^2 |0\rangle_{1H}|0\rangle_{1V}|0\rangle_{2H}|0\rangle_{2V}|0\rangle_{3H}|1\rangle_{3V} \right) \quad (3.45)
\end{aligned}$$

We now group the states and neglect those of order g^4 or higher (in probability):

$$\begin{aligned}
& |\kappa\alpha\rangle_{0H}|0\rangle_{0V} \\
& \left(a \left(\left(1 - \frac{g^2|\alpha|^2}{2}\right)\left(1 - \frac{\kappa^2 g^2|\alpha|^2}{2}\right) - e^{i\phi} g^2 |\alpha|^2 \kappa \left(1 - \frac{\kappa^2}{2}\right) \right) |0\rangle_{1H}|0\rangle_{1V}|0\rangle_{2H}|0\rangle_{2V}|1\rangle_{3H}|0\rangle_{3V} \right. \\
& + b \left(\left(1 - \frac{g^2|\alpha|^2}{2}\right)\left(1 - \frac{\kappa^2 g^2|\alpha|^2}{2}\right) - e^{i\phi} g^2 |\alpha|^2 \kappa \left(1 - \frac{\kappa^2}{2} + i\kappa\right) \right) |0\rangle_{1H}|0\rangle_{1V}|0\rangle_{2H}|0\rangle_{2V}|0\rangle_{3H}|1\rangle_{3V} \\
& + i g a \alpha \left(\kappa \left(1 - \frac{g^2|\alpha|^2}{2}\right) + e^{i\phi} \left(1 - \frac{\kappa^2}{2}\right) \left(1 - \frac{g^2}{2}(1 + 3\kappa^2|\alpha|^2)\right) \right) |0\rangle_{1H}|1\rangle_{1V}|0\rangle_{2H}|1\rangle_{2V}|1\rangle_{3H}|0\rangle_{3V} \\
& + g b \alpha \left(i\kappa \left(1 - \frac{g^2|\alpha|^2}{2}\right) + i e^{i\phi} \left(1 - \frac{\kappa^2}{2}\right) \left(1 - \frac{g^2}{2}(1 + 3\kappa^2|\alpha|^2)\right) - e^{i\phi} \kappa \left(1 - \frac{g^2}{2}(1 + 3\kappa^2|\alpha|^2)\right) \right) \\
& \quad |0\rangle_{1H}|1\rangle_{1V}|0\rangle_{2H}|1\rangle_{2V}|0\rangle_{3H}|1\rangle_{3V} \\
& \left. - e^{i\phi} g a \alpha \kappa \left(1 - \kappa^2 g^2 |\alpha|^2\right) |1\rangle_{1H}|0\rangle_{1V}|0\rangle_{2H}|1\rangle_{2V}|0\rangle_{3H}|1\rangle_{3V} \right) \quad (3.46)
\end{aligned}$$

We recall that we chose $\phi = \frac{\pi}{2}$, so that $e^{i\phi} = i$. Then, we simplify and neglect terms that do not contribute in order g^3 or less (in probability):

$$\begin{aligned}
& |\kappa\alpha\rangle_{0H}|0\rangle_{0V} \\
& \left(a \left(1 - \frac{g^2|\alpha|^2}{2} - ig^2|\alpha|^2\kappa \left(1 - \frac{i\kappa}{2} - \frac{\kappa^2}{2} \right) \right) |0\rangle_{1H}|0\rangle_{1V}|0\rangle_{2H}|0\rangle_{2V}|1\rangle_{3H}|0\rangle_{3V} \right. \\
& \quad + b \left(1 - \frac{g^2|\alpha|^2}{2} - ig^2|\alpha|^2\kappa \left(1 + \frac{i\kappa}{2} - \frac{\kappa^2}{2} \right) \right) |0\rangle_{1H}|0\rangle_{1V}|0\rangle_{2H}|0\rangle_{2V}|0\rangle_{3H}|1\rangle_{3V} \\
& + ig a \alpha \left(\kappa \left(1 - \frac{g^2|\alpha|^2}{2} \right) + e^{i\phi} \left(1 - \frac{\kappa^2}{2} \right) \left(1 - \frac{g^2}{2} (1 + 3\kappa^2|\alpha|^2) \right) \right) |0\rangle_{1H}|1\rangle_{1V}|0\rangle_{2H}|1\rangle_{2V}|1\rangle_{3H}|0\rangle_{3V} \\
& \quad + ig b \alpha \left(\kappa \frac{g^2}{2} (1 - |\alpha|^2 + 3\kappa^2|\alpha|^2) + i \left(1 - \frac{\kappa^2}{2} \right) \left(1 - \frac{g^2}{2} (1 + 3\kappa^2|\alpha|^2) \right) \right) \\
& \quad \quad |0\rangle_{1H}|1\rangle_{1V}|0\rangle_{2H}|1\rangle_{2V}|0\rangle_{3H}|1\rangle_{3V} \\
& \quad \quad \left. - e^{i\phi} g a \alpha \kappa (1 - \kappa^2 g^2 |\alpha|^2) |1\rangle_{1H}|0\rangle_{1V}|0\rangle_{2H}|1\rangle_{2V}|0\rangle_{3H}|1\rangle_{3V} \right) \quad (3.47)
\end{aligned}$$

Now, for simplicity, we consider that κ is of the order of \sqrt{g} , so that we can neglect the terms where their total g -order is higher than 3 (in probability):

$$\begin{aligned}
& |\kappa\alpha\rangle_{0H}|0\rangle_{0V} \\
& \left(a \left(1 - \frac{g^2|\alpha|^2}{2} - ig^2|\alpha|^2\kappa \left(1 - \frac{i\kappa}{2} \right) \right) |0\rangle_{1H}|0\rangle_{1V}|0\rangle_{2H}|0\rangle_{2V}|1\rangle_{3H}|0\rangle_{3V} \right. \\
& \quad + b \left(1 - \frac{g^2|\alpha|^2}{2} - ig^2|\alpha|^2\kappa \left(1 + \frac{i\kappa}{2} \right) \right) |0\rangle_{1H}|0\rangle_{1V}|0\rangle_{2H}|0\rangle_{2V}|0\rangle_{3H}|1\rangle_{3V} \\
& \quad + g a \alpha \left(i\kappa - \left(1 - \frac{\kappa^2}{2} \right) \right) |0\rangle_{1H}|1\rangle_{1V}|0\rangle_{2H}|1\rangle_{2V}|1\rangle_{3H}|0\rangle_{3V} \\
& \quad - g b \alpha \left(1 - \frac{\kappa^2}{2} \right) |0\rangle_{1H}|1\rangle_{1V}|0\rangle_{2H}|1\rangle_{2V}|0\rangle_{3H}|1\rangle_{3V} \\
& \quad \quad \left. - i g a \alpha \kappa |1\rangle_{1H}|0\rangle_{1V}|0\rangle_{2H}|1\rangle_{2V}|0\rangle_{3H}|1\rangle_{3V} \right) \quad (3.48)
\end{aligned}$$

To interpret this, we will group the terms where there are single photons, so that we can postselect them:

$$\begin{aligned}
& |\kappa\alpha\rangle_{0H}|0\rangle_{0V} \\
& \left(a \left(1 - \frac{g^2|\alpha|^2}{2} - ig^2|\alpha|^2\kappa \left(1 - \frac{i\kappa}{2} \right) \right) |0\rangle_{1H}|0\rangle_{1V}|0\rangle_{2H}|0\rangle_{2V}|1\rangle_{3H}|0\rangle_{3V} \right. \\
& + b \left(1 - \frac{g^2|\alpha|^2}{2} - ig^2|\alpha|^2\kappa \left(1 + \frac{i\kappa}{2} \right) \right) |0\rangle_{1H}|0\rangle_{1V}|0\rangle_{2H}|0\rangle_{2V}|0\rangle_{3H}|1\rangle_{3V} \\
& \quad - g\alpha \left(\left(1 - \frac{\kappa^2}{2} \right) |0\rangle_{1H}|1\rangle_{1V}|0\rangle_{2H}|1\rangle_{2V}|\psi\rangle_3 \right. \\
& \quad \quad - ia\kappa (|0\rangle_{1H}|1\rangle_{1V}|0\rangle_{2H}|1\rangle_{2V}|1\rangle_{3H}|0\rangle_{3V} \\
& \quad \quad \quad \left. \left. - |1\rangle_{1H}|0\rangle_{1V}|0\rangle_{2H}|1\rangle_{2V}|0\rangle_{3H}|1\rangle_{3V} \right) \right) \quad (3.49)
\end{aligned}$$

This means the following:

- The coherent state always ends up in $|\kappa\alpha\rangle_{0H}|0\rangle_{0V}$.
- When twin-photon emission occurs, there is a $\frac{1-\kappa^2/2}{|1-\kappa^2/2|^2+|a|^2\kappa^2}$ probability amplitude that $|0\rangle_{1H}|1\rangle_{1V}|0\rangle_{2H}|1\rangle_{2V}|\psi\rangle_3$ is the state of the twin photons and external system, i.e, that there has been no change on the external system (and the single photons are in vertical polarization).
- The rest of the times (when twin photon emission has occurred), the path-(2) photon is vertically polarized, and the state of the path-(1) photon and external system is $\frac{1}{\sqrt{2}}(|0\rangle_{1H}|1\rangle_{1V}|1\rangle_{3H}|0\rangle_{3V} - |1\rangle_{1H}|0\rangle_{1V}|0\rangle_{3H}|1\rangle_{3V})$, which means that they are entangled: if the photon is horizontally polarized, the external state is $|0\rangle_{3H}|1\rangle_{3V}$, and if it is vertically polarized, the external state is $|1\rangle_{3H}|0\rangle_{3V}$. This, however, does not yield any information about $|\psi\rangle$, which has been hidden.

We conclude that, whenever there is a twin emission, either nothing happens to the external state, or the state is hidden, so that none of its information can be accessed through normal polarization measurement on the single photons. This means that we can iterate the experiment until the latter case happens at least once, such that we have successfully hidden $|\psi\rangle$, and thus simulated a deletion. This time, however, $|\psi\rangle$ is a completely unknown state, seeing as we did not encode it classically, and we did not require to encode the parameter b in the coherent beam.

After many iterations of this process, there will be a high probability amplitude that we have realized an erasure of the information. We say “erasure” because the information of $|\psi\rangle$ should be accessible somewhere, but is no longer encoded in polarization. What is more, this erasure is a coherent process, since we have not

done anything that could potentially decohere (measure) the encoded information (an argument can be made about the polarizer on the coherent beam, but that can not possibly affect the single photon paths where $|\psi\rangle$ is encoded). Nevertheless, despite being a coherent erasure, the state $|\psi\rangle$ is not recoverable in a trivial manner.

Chapter 4

Relevance as No-Go Theorem

The No-Deleting Theorem can be viewed as a consequence of unitarity of quantum operators. An operator U is unitary if it yields the Identity operator when multiplying it by its conjugate transpose (on any order).

$$U^\dagger U = U U^\dagger = \mathbb{1} \quad (4.1)$$

This means that any arbitrary quantum operator must have an inverse, which is its conjugate transpose, and which is also a quantum evolution. This is why irreversible evolutions are deemed unphysical in quantum mechanics, because every evolution in quantum mechanics must be reversible.

The unitarity condition of operators is sufficient to forbid evolutions of the kind:

$$|\psi\rangle \rightarrow |c\rangle \quad (4.2)$$

or

$$\begin{aligned} |0\rangle &\rightarrow |c\rangle \\ |1\rangle &\rightarrow |c\rangle, \end{aligned} \quad (4.3)$$

which accounts for our Deleter model, and the No-Deleting Theorem in general.

We will now consider the No-Deleting Theorem without referring to the unitarity condition, to determine its relevance with respect to other No-Go Theorems.

4.1 Deleter and Signalling

The No-Signalling Theorem states that no instantaneous information transfer can result from a distant intervention [25]. This theorem forbids any instantaneous communication by means of an entangled state, solving the EPR paradox [26]. In

other words (taking relativity into account), no faster-than-light communication is possible.

We have already stated that Deletion would allow instantaneous communication by means of an entangled state. We will now propose a thought experiment to prove it. The result is not new, but our thought experiment is simpler than previous proofs [7].

Our experiment will be based on a biphoton state traversing a Franson interferometer [27], in which the time of creation of the two-photon state is uncertain (by an amount $\Delta t_{emission}$), a feature which will be explicitly exploited. Each one of the photons travels to different (eventually far-apart) regions of space, one of them heading towards Alice and the other one towards Bob (see Fig.4.1).

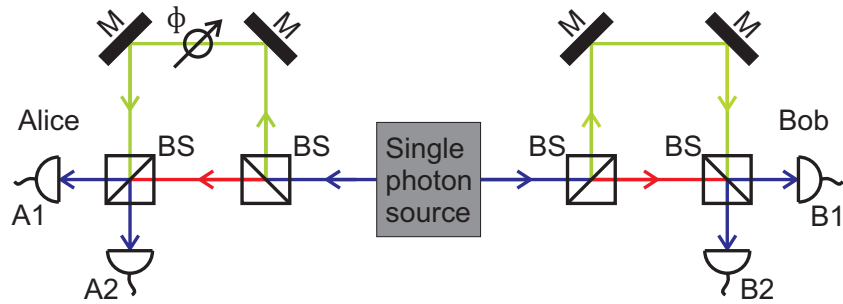

Figure 4.1: Two photons are emitted simultaneously in a single photon source. Each one of them can go through a long path L (in green) or a short path S (in red). M are mirrors, BS are beam-splitters, ϕ is a retarder, and $A1$, $A2$, $B1$, $B2$ are detectors.

Each one of the photons then traverses a Mach-Zehnder array that is sufficiently unbalanced so as to suppress first-order coherence (that is, interference of each photon with itself, irrespective of the other). At the output ports of each array are Alice's and Bob's detectors: $A1$, $A2$, $B1$ and $B2$ (A and B refer to Alice and Bob, and 1 and 2 to the output port of the Mach-Zehnder).

The biphoton state just before the photons go through the final beamsplitter of each array can be described by the following four possibilities: Alice's and Bob's photons go both through the short arm of each array (Eq.4.4a), both go through the long arms (Eq.4.4b) or one goes through the short arm and the other through

the long one (Eqs. 4.4c and 4.4d).

$$|S\rangle_A|S\rangle_B \quad (4.4a)$$

$$|L\rangle_A|L\rangle_B \quad (4.4b)$$

$$|S\rangle_A|L\rangle_B \quad (4.4c)$$

$$|L\rangle_A|S\rangle_B \quad (4.4d)$$

By doing coincidence detections, Alice and Bob can distinguish states (4.4d) and (4.4c) from (4.4b and (4.4a). This can be easily seen when Alice's and Bob's setups are symmetrical. If the state were SS or LL, detections would occur simultaneously. However, LS and SL events produce detections at different times, something that Alice and Bob can check afterwards, and then conveniently postselect SS and LL events. Thus, LS and SL do not interfere with LL and SS. On the other hand, SS and LL events are indistinguishable because both generate simultaneous detection events. Furthermore, when the length difference between long and short arms (Δl) is such that $\Delta l/c \ll \Delta t_{emission}$, interference between them can be observed. This joint state is given by 4.5.

$$\frac{|S\rangle_A|S\rangle_B + e^{i\phi}|L\rangle_A|L\rangle_B}{\sqrt{2}} \quad (4.5)$$

Note that we have already included the phase (ϕ) shown in Fig.(4.1). This phase is something that can only be determined by computing correlations between Alice's and Bob's measurements. Local measurements do not give any phase information whatsoever, as can be seen by calculating either Alice's or Bob's reduced density matrix (which is proportional to unity in this case). Even more, local operations (such as the beamsplitters') cannot change this situation. Alice and Bob would have to communicate through a classical channel to obtain the phase.

If Alice were to use a path-Deleter instead of her last beam-splitter, this situation would drastically change. The action of our deleter-model on this system is given by:

$$\begin{aligned} |S\rangle_A &\rightarrow |1\rangle_A \\ |L\rangle_A &\rightarrow |1\rangle_A \end{aligned} \quad (4.6)$$

The action on state 4.5 is given by:

$$\frac{|S\rangle_A|S\rangle_B + e^{i\phi}|L\rangle_A|L\rangle_B}{\sqrt{2}} \rightarrow \frac{|1\rangle_A(|S\rangle_B + e^{i\phi}|L\rangle_B)}{\sqrt{2}} \quad (4.7)$$

Alice's state is now separable and Bob can obtain ϕ with only local measurements, even if ϕ is controlled by Alice, whose setting of the phase could be causally disconnected from Bob's measurements. By choosing $\phi = 0$ or $\phi = \pi$, Alice can decide whether Bob receives $\frac{1}{\sqrt{2}}(|S\rangle_B + |L\rangle_B)$ or $\frac{1}{\sqrt{2}}(|S\rangle_B - |L\rangle_B)$. Then, Bob's last beam-splitter effects the following transformation:

$$\begin{aligned} \frac{1}{\sqrt{2}}(|S\rangle_B + |L\rangle_B) &\rightarrow |1\rangle_B \\ \frac{1}{\sqrt{2}}(|S\rangle_B - |L\rangle_B) &\rightarrow |2\rangle_B, \end{aligned} \tag{4.8}$$

where $|1\rangle_B$ is the path that leads to detector B1, and $|2\rangle_B$ is the path that leads to detector B2. This way, Alice can decide whether Bob's photon reaches detector B1 or B2, thereby establishing a superluminal communication protocol.

We remark that no communication between Alice and Bob is needed to sort out LS and SL events apart. They just contribute a constant background of detections for Bob (the same for both detectors).

This way, we have shown that a violation of the No-Deleting Theorem implies a violation of the No-Signalling Theorem in the context of Quantum Mechanics. Thus, (in the context of Quantum Mechanics) the No-Signalling theorem implies the No-Deleting Theorem.

4.2 Deleter and Second Law

To determine the relation between Deletion and the Second Law of Thermodynamics, we must determine the change in entropy after a deletion process. For this, we will consider the von Neumann entropy, defined as $-Tr(\rho \ln \rho)$, where ρ is the density matrix of the state of interest. We will, however, use the alternate definition made by Shannon for information theory [28], where \log_2 is used instead of \ln (this is the *Shannon* or *bit* entropy). This is done for convenience and to provide consistency with other articles on this topic [3]. Still, we could instead use the von Neumann entropy for anything done in this chapter.

4.2.1 Entropy in a Deleter

It is relatively easy to prove that a deletion evolution can affect the Shannon entropy of a state in a closed system. As a rule of thumb, the higher the entropy, the bigger the space spanned by the possible values of the state.

Consider the following deletion evolution:

$$|\psi\rangle \rightarrow |c\rangle \quad (4.9)$$

$|\psi\rangle$ is an arbitrary qubit and $|c\rangle$ a constant, known qubit (for simplicity, all states will be two-level systems). The input spans the complete two-dimensional Hilbert space of one qubit, since it is arbitrary, whereas the output is a known (pure) state, so it only spans a point in the one-dimensional Hilbert space. The (Shannon) entropy decreases from $\log_2 2$ to 0.

Let us note that an arbitrary state $|\psi\rangle$ is treated as a mixed state of all the possible $|\psi\rangle$, i.e., half the identity operator ($\mathbb{1}/2$), the fully random state in the space of one qubit. Because of this reason, an arbitrary state $|\psi\rangle$ has Shannon entropy of 1.

The Shannon entropy decreases also in deletion evolutions against a copy:

$$|\psi\rangle|\psi\rangle \rightarrow |\psi\rangle|c\rangle \quad (4.10)$$

In this example, taken from [3], $|\psi\rangle|\psi\rangle$ spans a three-dimensional subspace of the Hilbert space of two qubits. This is because an arbitrary $|\psi\rangle|\psi\rangle$ can be expressed as linear combinations of $|0\rangle|0\rangle$, $|1\rangle|1\rangle$ and $(|0\rangle|1\rangle + |1\rangle|0\rangle)$, which spans a three-dimensional Hilbert space. On the other hand, $|\psi\rangle|c\rangle$ spans only a two-dimensional subspace. This way, this change from identity in three-dimensional Hilbert space to identity in two-dimensional Hilbert space decreases Shannon entropy from $\log_2 3$ to $\log_2 2$.

We can conclude that the Shannon entropy is decreased in a closed system when we perform a deletion (with or without a copy), something that will be useful to relate it to the Second Law of Thermodynamics. However, before proceeding we must note that we have proven this only for parametric evolutions, i.e, evolutions in which the state of the “deleter-device” is invariant and does not need to be taken into account.

Does this hold when we use a more general model for a deleter, including a state for the deleter-device? We will now write the device as a prepared (known) ancilla state $|\phi\rangle$ (and get back to deletion without a copy):

$$|\psi\rangle|\phi\rangle \rightarrow |c\rangle|\phi_\psi\rangle \quad (4.11)$$

If this device is to be a Deleter, the information of $|\psi\rangle$ must not be recoverable from $|\phi_\psi\rangle$. This means that there should not be a function that maps $|\phi_\psi\rangle$ to $|\psi\rangle$ for all $|\psi\rangle$.

For this, there are two alternatives:

- either there is no function f that maps $|\psi\rangle$ to $|\phi_\psi\rangle$, and the evolution is intrinsically random
- or there is such a function f (so that the evolution is deterministic), and it is not a one-to-one function, i.e, two or more values of $|\psi\rangle$ are (always) mapped into the same $|\phi_\psi\rangle$.

Intrinsically Random Deletion

If there can not possibly be a function that maps all $|\psi\rangle$ to their respective $|\phi_\psi\rangle$ (given that $|\phi\rangle$ is known), and there is no other hidden variable that can be a parameter of the function (because this is a closed system), it means that any mapping done between $|\psi\rangle$ and $|\phi_\psi\rangle$ is intrinsically random.

This may remind us of a measurement process, but there is an important difference: we speak of measurements (and their intrinsic randomness) only when we refer to open systems, because the measuring apparatus, observer or environment which get entangled with the system are never completely described. This deletion process is intrinsically random, but in a *closed* system: everything described is all there is to it. Before continuing, we will go a little deeper on this comparison, and try to answer the question formulated in the first chapter, regarding the *irreversibility* of classical erasure.

A measurement is considered *irreversible* only within the limits of the open system of interest. To reverse a measurement, everything about it would have to be reversed, including changes in the measuring apparatus, environment and memory storing processes of the observer (if there is one). If we consider all of this within the system, a measurement is *irreversible* only in that it is very impractical. The same can be said about erasure, because classical information erasure can be achieved reversibly only if the system is known (has been measured). We are reminded that -as we stated before- erasure is somehow equivalent to measurement.

This way, to answer the question on the first chapter, erasure can be effectively *irreversible*, but only in an open system, whereas the word “deletion” is used when referring to closed systems -frequently in the context of quantum mechanics-, and it means an actually irreversible process. Classical and quantum information are treated differently because quantum systems decohere only in open systems (something that is not an issue for classical systems), and are thus better depicted in closed systems.

Now that we have partially addressed the question, we will continue with the analysis of the Shannon Entropy in an Intrinsically Random Deletion.

First of all, if the deletion is intrinsically random, we should not express the output with the term $|\phi_\psi\rangle$, which is a pure state, but with a mixed state ρ_ψ . This mixed state can have a Shannon entropy between 0 and $\log_2 2$ (0 when it is closest to being a pure state, and $\log_2 2$ when it is the maximally mixed state).

This way, for this deletion evolution:

$$|\psi\rangle|\phi\rangle \rightarrow |c\rangle\rho_\psi \quad (4.12)$$

The Shannon entropy is decreased unless ρ_ψ is the maximally mixed state. In that case, it remains constant ($\log_2 2$). We note that entropy can be conserved despite the fact that there has been a Deletion evolution.

A way to see this entropy invariance is that an “intrinsically random” evolution in a closed system creates new information in it (even if it is closed), since the outcome of the evolution is information that can not be determined before the evolution but can be known after it (if -within a system- something can not be known before time t , but can be known after time t , it means that some information has entered the system at that time).

However, entropy can not be conserved for all systems. We will consider again the case in which ρ_ψ is the maximally mixed state. Let's say that we have another copy of $|\psi\rangle$ during the evolution, which remains unchanged, such that 4.12 is still a valid description. We now have:

$$|\psi\rangle|\psi\rangle|\phi\rangle \rightarrow |\psi\rangle|c\rangle\rho_\psi \quad (4.13)$$

This time the input has an entropy of $\log_2 3$, while the output has an entropy of $2\log_2 2$. The entropy in this new system has increased despite being constant from the other point of view (we have just added a parametric state).

We can say that in some cases an intrinsically random deletion evolution can leave the Shannon entropy invariant, but that no longer holds when we extend the system with a parametric copy of the state (to be deleted). This way, -in general- entropy is not conserved in intrinsically random deletions.

Deterministic Deletion

In the latter kind of deletion, there exists a function that maps $|\psi\rangle$ to $|\phi_\psi\rangle$ (given $|\phi\rangle$), but it is not a one-to-one function. As we said, this means that at least two inputs of the function (say $|\psi_1\rangle$ and $|\psi_2\rangle$) are mapped into the same output ($|\phi_c\rangle$). We now write the related deletion process:

$$\begin{aligned}
|\psi_1\rangle|\phi\rangle &\rightarrow |c\rangle|\phi_c\rangle \\
|\psi_2\rangle|\phi\rangle &\rightarrow |c\rangle|\phi_c\rangle
\end{aligned}
\tag{4.14}$$

Let's say we send a state into the deleter-device with one of two different (linearly independent) states: $|\psi_1\rangle$ or $|\psi_2\rangle$ (a mixed state). The deleter is set into $|\phi\rangle$, a known state, so our total Shannon entropy for the input (deleter included) will be higher than 0 (the Shannon entropy measures the departure of the system from a pure state). The output (deleter included), on the other hand, is completely determined ($|c\rangle|\phi_c\rangle$), and a pure state, so it has a Shannon entropy of 0.

This way, we can conclude that a Deterministic Deletion entails a decrease in Shannon entropy. Note that Deletion with a parametric deleter-device is a particular case of Deterministic Deletion.

Deletion with Cloning

There is one additional case we need to consider regarding the relation of a deleter process with the loss of (Shannon) entropy in a closed system, even though it is rather specific. Let $|\psi\rangle$ and $|\phi\rangle$ be both arbitrary states in the following deletion and cloning evolution:

$$|\psi\rangle|\psi\rangle|\phi\rangle \rightarrow |\psi\rangle|\phi\rangle|\phi\rangle \tag{4.15}$$

This does not directly violate the formulations for the No-Deleting and No-Cloning theorem, but –in a way– the state $|\psi\rangle$ has been deleted, and the state $|\phi\rangle$ cloned, so this is an unphysical evolution. Proof of it is that Signalling is possible under transformation 4.15.

The (Shannon) entropy, on the other hand, is constant (and equal to $\log_2 3 + 1$). Regarding the entropy, deletion and cloning can cancel each other out, even if we delete and clone different states.

From here onward, we will consider the No-Deleting and No-Cloning Theorems to include the forbiddance of this case. Specifically, we will consider No-Deleting and No-Cloning Theorems in which not only does total information matter, but also partial information. As we have seen, total information can be conserved when there is a partial information cloning and a partial information deleting.

4.2.2 From Second Law to No-Deleting

To conclude that there is implication between Deleting and breaking the Second Law of Thermodynamics, we must treat the Shannon entropy and the thermody-

dynamic entropy as different expressions for the same concept. This is a reasonable agreement, because we can exchange Shannon's entropy with von Neumann's entropy for all proofs in this chapter, and von Neuman's work was an approach from thermodynamics (the only difference is the lack of Boltzmann constant), not from information theory [29]. Other recent formulations of the von Neumann entropy do start from information theory, though, such as Asher Peres' [25].

This way, in closed systems, all deletion evolutions decrease thermodynamic entropy, and thus break the Second Law of Thermodynamics, so long as we consider the evolution parametric (or non intrinsically random in general) and forbid simultaneous partial deletion and cloning.

As we pointed out before, intrinsic randomness in a closed system can be interpreted as the creation of new information. This is also true for the (unphysical) cloning process, in which information can increase in a closed system. Deletion without intrinsic randomness, on the other hand, can be interpreted as a decrease of information in a closed system.

We can say the following: If information can not be simultaneously partially increased and decreased in a closed system (for example, by simultaneously deleting and cloning different unknown states, as in 4.15), the Second Law of Thermodynamics implies the No-Deleting Theorem. Here, we have reached a similar conclusion to the one obtained in [3], albeit with a consideration.

In an analogous way, we could prove that: if there can not be simultaneous partial information increase and decrease (SPIID) in a closed system, the Second Law of Thermodynamics (stated as no-increase of thermodynamic entropy in a closed system) implies the No-Cloning Theorem. The argument will -again- be the same one used in [3], with the mentioned consideration.

Thus, we have the following, regarding a closed system:

$$\begin{aligned} \left(\text{No-SPIID} \wedge \text{Second Law (no decrease of entropy)} \right) &\implies \text{No-Deleting} \\ \left(\text{No-SPIID} \wedge \text{Second Law (no increase of entropy)} \right) &\implies \text{No-Cloning} \end{aligned} \quad (4.16)$$

Here, we state the Second-Law both as no-increase and no-decrease of thermodynamic entropy.

The assertions in 4.16 are equivalent to:

$$\begin{aligned} \text{No-SPIID} &\implies \left(\text{Second Law (no decrease of entropy)} \implies \text{No-Deleting} \right) \\ \text{No-SPIID} &\implies \left(\text{Second Law (no increase of entropy)} \implies \text{No-Cloning} \right) \end{aligned} \quad (4.17)$$

We now join the two assertions:

No-SPIID \implies

$$\left(\text{Second Law (conservation of entropy)} \implies (\text{No-Deleting} \wedge \text{No-Cloning}) \right) \quad (4.18)$$

This way, we conclude that, unless we consider the possibility of a simultaneous double-unphysicality (SPIID), the Second Law of Thermodynamics (stated as both no increase and no decrease of entropy) implies the No-Deleting and No-Cloning Theorem. This is a statement that relates the conservation of thermodynamic entropy with the conservation of information.

We are mostly interested, however, in the standard “no-decrease of entropy in a closed system” Second Law. So far, we have shown that this implies the No-Deleting Theorem (assuming no SPIID). Can we prove the reciprocal?

4.2.3 From No-Deleting to Second Law

We will now start with a violation of the Second Law (“no-decrease of entropy”), from a thermodynamic point of view.

A violation of the second law implies that we could extract heat from a reservoir and convert it all into work. This will be the first thing we will prove, starting with a violation of the Second Law, as formulated in terms of Carnot’s Heat Engine. We will then show that this can be used to delete quantum information.

Carnot’s Cycle

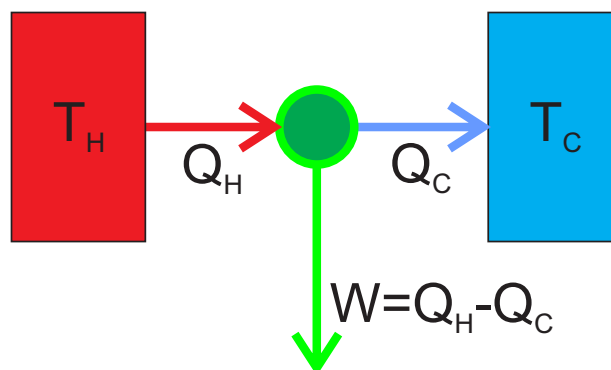

Figure 4.2: A heat engine is made with two systems at different temperatures (T_H for the hotter system, and T_C for the colder one), such that heat flows from the hot system to the cold system. This process can be used to extract work, and the Carnot cycle holds the maximum work (W) that can be extracted per unit of heat that is taken from the hot system (efficiency).

The Carnot cycle holds the maximum efficiency for a Heat Engine (work per unit of heat taken from the hot system), with a value of $\eta = 1 - \frac{T_C}{T_H}$ [30], where T_C is the (absolute) temperature of the cold system, and T_H the temperature of the hot system. The heat received by the cold system is the heat taken from the hot system minus the work extracted, so even if we considered the efficiencies past Carnot's (but still less than 1), energy would be conserved.

For a Carnot cycle, given the temperatures of the systems (T_H and T_C) and the heat extracted from the hot system (Q_H), we determine the extracted work to be:

$$W = Q_H \left(1 - \frac{T_C}{T_H}\right) \quad (4.19)$$

and the heat released on the cold system is:

$$Q_C = Q_H \frac{T_C}{T_H} \quad (4.20)$$

Now suppose we have a heat engine that allows a slight violation of the Second Law, that is, an engine slightly more efficient than the Carnot cycle [30]:

$$\eta = \frac{W}{Q_H} = 1 - \frac{T_C}{T_H} + \frac{\Delta W}{Q_H} \quad (4.21)$$

This way, given the temperatures of the systems (T_H and T_C) and the heat extracted from the hot system (Q_H), we determine the extracted work to be:

$$W = Q_H \left(1 - \frac{T_C}{T_H}\right) + \Delta W \quad (4.22)$$

and the heat released on the cold system to be:

$$Q_C = Q_H \frac{T_C}{T_H} - \Delta W \quad (4.23)$$

The Carnot cycle is reversible, so it is possible to have a Carnot refrigerator. Its efficiency is usually stated as “heat extracted from the cold system per unit of work used on the engine”, but we do not actually need to write it down. We can obtain the desired quantities for the reversed Carnot cycle simply by considering that it should cancel out an applied Carnot cycle.

Given the temperatures of the systems (T_H and T_C) and the heat *received* by the hot system (Q_H), the *necessary* work for a Carnot refrigerator is:

$$W_{\text{Carnot}} = Q_H \left(1 - \frac{T_C}{T_H}\right) \quad (4.24)$$

and the heat extracted from the cold system is:

$$Q_{\text{Carnot}} = Q_H \frac{T_C}{T_H} \quad (4.25)$$

We now couple our Second-Law violating Heat Engine with the reversed Carnot cycle.

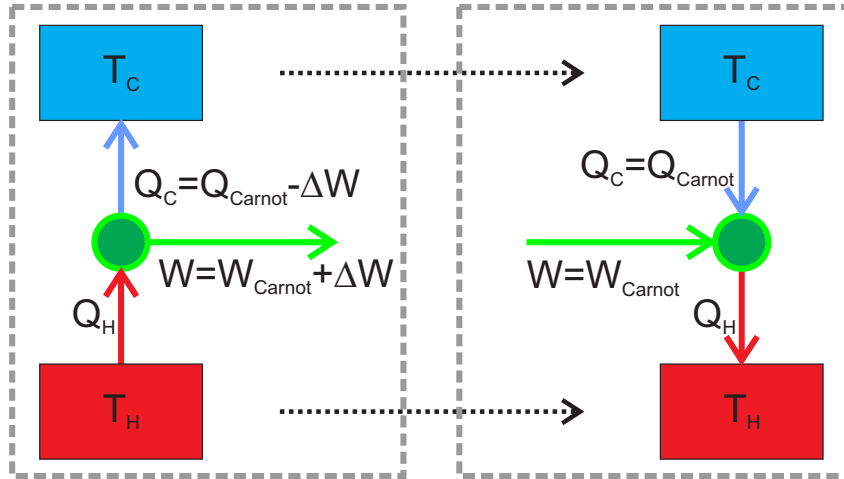

Figure 4.3: We couple a heat engine with a slight violation of the Second Law with a reversed Carnot cycle (a Carnot refrigerator).

When we do this, we get an engine that extracts work from the heat of a single system in equilibrium (see figure 4.4), which is what we wanted to prove.

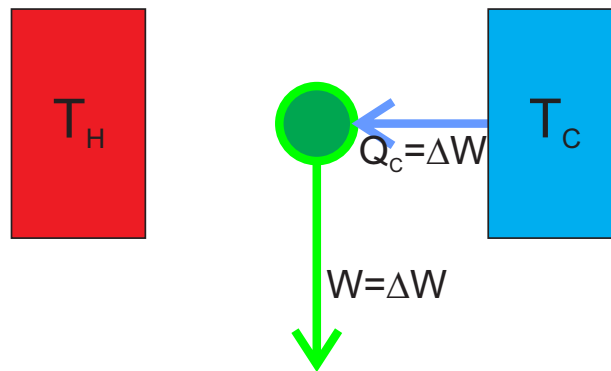

Figure 4.4: The coupled engines are equivalent to an engine that extracts heat from a single system and turns it into work. We will not dispense with the hot system yet, as it still interacts with the cold engine in ways that are not taken into account by thermodynamics.

Note that we are potentially violating the Kelvin statement of the Second Law, and also note that we can directly violate the Clausius statement by releasing the extracted work on the hot system (and thus moving heat from the cold to hot system without expending any work).

We may be tempted to remove the system at temperature T_H from our description of the coupled engine, but thermodynamics describes only macrostates, whereas if we are to relate this with the No-Deleting Theorem, which belongs to quantum mechanics, we need to take the microstates into account too.

Since our two systems have interacted with each other on each part of the engine, if we want to consider the microstates, we can not dispense with any of the systems, even if the thermodynamic macrostates indicate that there is no net change in one of the systems.

In our thought experiment, these two systems will interact with other systems only when we state so, so they will be closed from everything else, and we need not worry for more microstates “spilling out”.

To prove that this can be used to perform quantum deletion, we will use the ΔW work obtained from each iteration of our engine to make Landauer erasure processes. The Landauer erasure process is -however- for bits of classical information, not for qubits of quantum information, and we are not interested in erasing classical information, but in erasing quantum information. We will solve this issue with the quantum teleportation protocol [5].

Quantum teleportation

In the normal teleportation protocol, Alice possesses an arbitrary state $|\psi\rangle = \alpha|0\rangle_A + \beta|1\rangle_A$ and wants to send its information to Bob. To do so, they share beforehand a maximally entangled pair $\frac{1}{\sqrt{2}}(|0'\rangle_A|0\rangle_B + |1'\rangle_A|1\rangle_B)$ (Alice keeps the first qubit and Bob keeps the second).

Then, Alice performs a C-NOT gate between her arbitrary state and her part (qubit) of the entangled pair, where the arbitrary state is the control qubit. The complete system is now:

$$\frac{1}{\sqrt{2}}(\alpha|0\rangle_A|0'\rangle_A|0\rangle_B + \alpha|0\rangle_A|1'\rangle_A|1\rangle_B + \beta|1\rangle_A|1'\rangle_A|0\rangle_B + \beta|1\rangle_A|0'\rangle_A|1\rangle_B), \quad (4.26)$$

where the first qubit corresponds to the originally arbitrary state, and the second and third to Alice’s and Bob’s entangled pairs, respectively.

Now, Alice applies a Hadamard transform on her first qubit, obtaining:

$$\frac{1}{2} \left(|00'\rangle_A (\alpha|0\rangle_B + \beta|1\rangle_B) + |01'\rangle_A (\alpha|1\rangle_B + \beta|0\rangle_B) \right. \\ \left. + |10'\rangle_A (\alpha|0\rangle_B - \beta|1\rangle_B) + |11'\rangle_A (\alpha|1\rangle_B - \beta|0\rangle_B) \right), \quad (4.27)$$

which we can write in terms of $|\psi\rangle$ and the pauli matrices (\hat{X} , \hat{Y} and \hat{Z}):

$$\frac{1}{2} \left(|00'\rangle_A (|\psi\rangle_B) + |01'\rangle_A (\hat{X}|\psi\rangle_B) + |10'\rangle_A (\hat{Z}|\psi\rangle_B) + |11'\rangle_A (\hat{X}\hat{Z}|\psi\rangle_B) \right) \quad (4.28)$$

We can easily note that, if Bob were to measure his qubit without considering his correlations with Alice, he would obtain a maximally mixed state, because an equiprobabilistic ensemble of the identity and pauli evolutions on any arbitrary state is a maximally mixed state ($\hat{X}\hat{Z}$ is -save for global phase- equal to \hat{Y}). This means that such an ensemble does not provide any information about the arbitrary state, and that Bob can not find anything about $|\psi\rangle$ by single counts only (also, if he could, we would have a problem with instantaneous messaging).

The next step in the protocol is for Alice to measure the first two qubits in the canonical basis and, depending on the result, tell Bob which gate (Identity or Pauli gate) he has to apply on his qubit to reconstruct $|\psi\rangle$. Basically, Alice needs to send the two bits of her measurements to Bob.

This is where we will depart from the normal teleportation protocol. We now have two qubits that, when measured, will give us two bits, which are enough information to reconstruct our initial arbitrary state on a third qubit. Our arbitrary qubit can be reconstructed as long as those two bits are knowable. If we erase any of those bits, the information of the qubit will be erased too (partially erased if we erase one; completely erased if we erase both).

However, there is a trick in that, when performing the measurements we should not be able to retrieve the information of the bit (or bits) we are to erase. Otherwise, the qubit information would be accessible. This is specially sensible because bit information can be copied, so even if we are sure a bit has arrived safely at an otherwise closed system, we can not be certain that its classic information was not copied and is accessible to an observer outside of that system.

For simplicity, let's say we will erase only one of the two bits, as partial erasure of $|\psi\rangle$ is enough for us. To avoid the possibility of retrieving the bit information, we will let the respective qubit (the one that yields the bit in question when measured) arrive at our "safe", closed (unless when stated otherwise) system: the system at

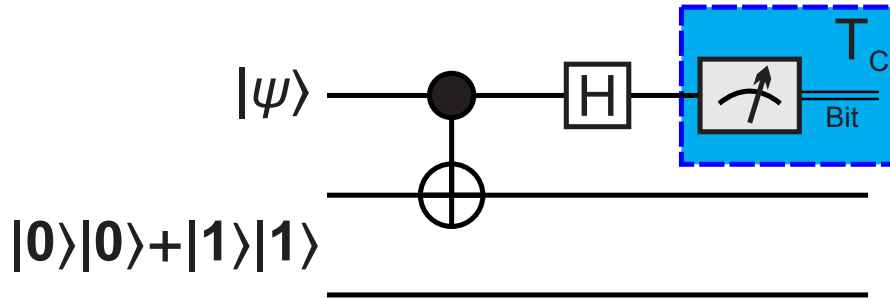

Figure 4.5: In the teleportation protocol, Alice (first and second qubit in the circuit) attempts to send an arbitrary state $|\psi\rangle$ to Bob (third qubit in the circuit). She does this by entangling her qubit with one of the qubits of a pre-shared EPR state (between herself and Bob). If (after applying a Hadamard) she then measured her qubits and sent the results to Bob (classical information), this would be enough for him to reconstruct state $|\psi\rangle$. In our tweak of the quantum teleportation protocol, Alice will instead measure and (Landauer) erase one of her qubits inside of a closed system, so that the bit's information is hidden (only accessible in the closed system), and the arbitrary state $|\psi\rangle$ is as well.

temperature T_C , from last section. Here we will do a Landauer erasure process for those qubits (which causes loss of coherence, equivalent to measuring) using the work we obtained in our coupled engine (see figures 4.5 and 4.6). We consider the system at temperature T_C as a reservoir so large that it is also considered an environment (so that it decoheres into energy eigenstates).

We set ΔW to be equal to the maximum possible cost for erasure, for convenience. This way, we measure the qubit, reset it to $|0\rangle$, release a heat in average equal to $k_B T_C \ln(2)$, and send the rest of the work as heat into the cold system. In total, it receives ΔW heat, which compensates the heat lost when we first applied the coupled engine. We then release the -now blank- qubit out of the system.

The net effect is to leave the two systems thermodynamically invariant (we do not state anything about their microstates yet) and dump the bit information required to reconstruct $|\psi\rangle$ into one of the systems.

It would apparently seem that this bit information is stored on the two (or one of the two) systems of the engine, in the form of heat, making $|\psi\rangle$ recoverable, and this would be true in normal scenarios. However, we can repeat this process as many times as we want, with different arbitrary states. If the classical bit storage capacity of a finite system at certain temperature is finite too -something that is very reasonable-, after many iterations we can prove that not all bits can be possibly written on the systems. Eventually some of those bits will be unknowable, and so will be their respective qubit, thus *deleting* it.

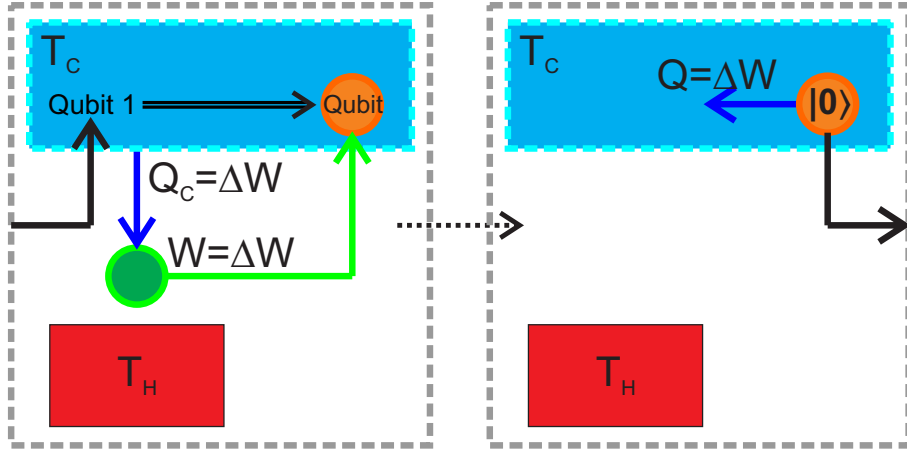

Figure 4.6: To erase the classical information from the first qubit of the circuit in 4.5, so that $|\psi\rangle$ is partially erased, we send that qubit (qubit 1) into the cold system used in our unphysical heat-to-work engine (figure 4.4). Using the ΔW work obtained from our unphysical engine, which was directly converted from heat extracted from the cold system, we perform inside of it a Landauer erasure process of qubit 1. The cold system is so big, it is considered an environment and decoheres (*measures*) the system into energy eigenstates after the erasure. The qubit is reset to $|0\rangle$ and a heat of $k_B T_C \ln(2)$ (in average) is released back into the cold system. Then, the rest of the work is dissipated in the form of heat into the environment, so that a total of ΔW heat has been released. After that, the qubit $|0\rangle$ is released from the system. This way, we have erased qubit 1 into the cold system (that is, we left its information as heat in the system) without any work expenditure, heat increase on the system, or heat release outside of it. This allows for the process to be repeated as many times as we want, for different $|\psi\rangle$.

This does not mean that the deletion occurs only after that many tries. We propose that the deletion actually occurs when the heat released by a Landauer erasure process of one of the bits is converted into work due to a subsequential application of our coupled (unphysical) engine. This would be explained by the possibility of extracting work by measuring and erasing that we mentioned before.

We could say that useful work can be obtained from *erased* heat, and also from *measured* heat. Our engine freely (without additional costs or emissions) converts heat into work, which would mean that it erases the information hidden in the heat, but without any cost or emission, thus deleting its information.

This way, we conclude that if the Second Law of Thermodynamics (of no decrease of entropy in a closed system) is broken, so will be the No-Deleting Theorem (given the reasonable assumption that finite systems with finite temperature can only hold finite information). This means that the No-Deleting Theorem implies the Second Law of Thermodynamics.

Since we already proved the reciprocal for cases in which there is no simultaneous

partial information increase and decrease (e.g, deleting and cloning at the same time like 4.15), this means that, given those considerations, the Second Law and the No-Deleting Theorem are equivalent No-Go Theorems.

Chapter 5

Conclusions

In this thesis, we have centered our attention in the No-Deleting Theorem, a theorem that comes from the unitarity condition in quantum mechanics. We have reviewed its statement and proof, as well as those of the No-Cloning Theorem, where cloning is the time-inverse of deletion (against a copy).

We have also reviewed a thermodynamic No-Go Theorem: the Second Law of Thermodynamics. We have resorted to Maxwell's Demon and Landauer's Principle to consider thermodynamics in the context of information. This leads us to the notion of an equivalence between measurement and erasure, in that they both can be used to extract the same amount of useful work from a system, and also require the same amount of work in order to be performed.

We have also proposed a photonic setup that realizes a Deletion simulation by use of spontaneous parametric down-conversion (and its inverse process) in a BBO crystal. This setup transfers the information of an unknown qubit encoded in a 2-Fock space of an arbitrary system into another 2-Fock space: one of the two single photons emitted by a BBO (horizontal and vertical polarization being each a photon-number Fock space). After that, the two single-photons and coherent beam (which originally pumped the BBO) are joined again, into a second BBO, in such a way that the encoded qubit information is partially hidden in the *no-photon* states. This way, we will not be able to measure the qubit by measuring the twin photons alone, since -when measured- they correspond to *1-photon* states (either vertically or horizontally polarized). Besides being a deletion simulation, this proves to be a coherent erasure process.

Finally, to pinpoint the relevance of the No-Deleting Theorem, we have compared it to other No-Go Theorems.

We have shown -with a thought experiment- that the No-Signalling Theorem implies the No-Deleting Theorem in the context of quantum mechanics, as proved

in [7].

Then, we linked the No-Deleting Theorem to the Second Law of Thermodynamics:

- Following a similar logic to [3], we conclude that the Second Law of Thermodynamics implies the No-Deleting Theorem (and also the No-Cloning Theorem). This is the same conclusion obtained in [3], albeit with a consideration: Simultaneous partial information increase and decrease in a closed system is the exception to this rule, as it can actually break the No-Deleting Theorem without breaking the Second Law of Thermodynamics. This consideration works under the logic that if we Delete an arbitrary state and clone another arbitrary state, we are still breaking the No-Deleting and No-Cloning theorem, despite the fact that total information is conserved (as well as total entropy).
- We also show the reciprocal with a thought experiment: that the No-Deleting Theorem implies the Second Law of Thermodynamics. For this, we only use the reasonable assumption that a finite system with finite temperature can only hold finite information.

With these two points, and under the stated considerations, we prove that the No-Deleting Theorem is an equivalent No-Go Theorem to the Second Law of Thermodynamics.

This way, we have attained a coherent erasure whilst simulating Deletion, and we have shown the high relevance of the No-Deleting Theorem. The latter was done by showing that its violation could be used for instantaneous signalling, and by proving its equivalence (given our considerations) with the Second Law of Thermodynamics. Of particular interest is the fact that the Second Law, which was considered to be emergent from pure statistics -something that may make us dismiss it as non fundamental-, is equivalent to a fundamental forbiddance in nature: the No-Deleting Theorem.

Bibliography

- [1] A. Zeilinger, *A Foundational Principle for Quantum Mechanics*, Foundations of Physics **29**, 4 (1999), 631–643.
- [2] C. Brukner and A. Zeilinger, *Information and Fundamental Elements of the Structure of Quantum Theory*, Springer. **Time, Quantum and Information** (2003), 323–354.
- [3] M. Horodecki, R. Horodecki, A. Sen, and U. Sen, *No-deleting and no-cloning principles as consequences of conservation of quantum information*, Arxiv **May** (2003), 0306044.
- [4] R. Landauer, *Irreversibility and heat generation in the computing process*, IBM Journal of Research and Development **5(3)** (1961), 183–191.
- [5] C. H. Bennett, *Notes on Landauer’s principle, Reversible Computation and Maxwell’s Demon*, Studies in History and Philosophy of Modern Physics **34(3)** (2003), 501–510.
- [6] A. K. Pati and S. L. Braunstein, *Impossibility of Deleting an Unknown Quantum State*, Nature **404** (2000), 104.
- [7] A. K. Pati and S. L. Braunstein, *Quantum deleting and signalling*, Physics Letters A **315** (2003), 208–212.
- [8] D. Dieks, *Communication by EPR devices*, Physics Letters A **92** (1982), 271–272.
- [9] W. K. Wootters and W. H. Zurek, *A single quantum cannot be cloned*, Nature **299** (1982), 802–803.
- [10] S. Carnot, *Reflections on the Motive Power of Heat*, New York: J. Wiley and Sons, 1890.

- [11] M. Kostic, *Revisiting The Second Law of Energy Degradation and Entropy Generation: From Sadi Carnot's Ingenious Reasoning to Holistic Generalization*, AIP Conf. Proc. **1411**, **327** (2011), <http://dx.doi.org/10.1063/1.3665247>.
- [12] R. Clausius, *On a Modified Form of the Second Fundamental Theorem in the Mechanical Theory of Heat*, Philos. Mag. **4**, **12 (77)** (1856), 81–98.
- [13] L. K. W. Thomson), *On the Dynamical Theory of Heat, with numerical results deduced from Mr Joules equivalent of a Thermal Unit, and M. Regnaults Observations on Steam*, Mathematical and Physical Papers **1**, **XLVIII** (1851), 174.
- [14] M. W. Zemansky, *Heat and Thermodynamics, 5th ed.: An Intermediate Textbook*, McGraw-Hill, New York, 1968.
- [15] L. Szilard, *On the reduction of entropy in a thermodynamic system by the intervention of intelligent beings*, Zeitschrift für Physik **53** (1929), 840–856.
- [16] B. Piechocinska, *Information erasure*, Phys. Rev. A **61** (2000), 062314.
- [17] J. Schneeloch and J. Howell, *Introduction to the Transverse Spatial Correlations in Spontaneous Parametric Down-Conversion through the Biphoton Birth Zone*, Arxiv **December** (2015), <http://arxiv.org/abs/1502.06996>.
- [18] X. Y. Zou, L. J. Wang, and L. Mandel, *Induced coherence and indistinguishability in optical interference*, Phys. Rev. Lett. **67** (1991), 318.
- [19] T. H. Johnson, S. R. Clark, and D. Jaksch, *What is a quantum simulator?*, EPJ Quantum Technology **1** (2014), 10.
- [20] X. Zhang, Y. Shen, J. Zhang, J. Casanova, L. Lamata, E. Solano, M. H. Yung, J. N. Zhang, and K. Kim, *Time reversal and charge conjugation in an embedding quantum simulator*, Nature Communications **6** (2015), 7917.
- [21] L. Mandel and E. Wolf, *Optical Coherence and Quantum Optics*, Cambridge University Press **1** (1995), 1088–1093.
- [22] T. J. Herzog, J. G. Rarity, H. Weinfurter, and A. Zeilinger, *Frustrated two-photon creation via interference*, Phys. Rev. Lett. **72** (1994), 629–632.
- [23] G. Lemos, V. Borish, G. Cole, S. Ramelow, R. Lspkiewicz, and A. Zeilinger, *Quantum imaging with undetected photons*, Nature **512** (2014), 409–412.

- [24] F. de Zela, *Two-component gadget for transforming any two nonorthogonal polarization states into one another*, Physics Letters A **19** (2012), 1664–1668.
- [25] A. Peres and D. R. Terno, *Quantum information and relativity theory*, Rev. Mod. Phys. **76** (2004), 93.
- [26] A. Einstein, B. Podolsky, and N. Rosen, *Can Quantum-Mechanical Description of Physical Reality Be Considered Complete?*, Phys. Rev. Lett. **47** (1935), 777.
- [27] J. D. Franson., *Bell inequality for position and time*, Phys. Rev. Lett. **62** (1989), 2205.
- [28] C. Shannon, *A mathematical theory of communication*, Bell System Techn. J. **27** (1948), 379423; 623656.
- [29] A. Deville and Y. Deville, *Clarifying the link between von Neumann and thermodynamic entropies*, The European Physical Journal H **38, 1** (2013), 57–81.
- [30] R. P. Feynman, R. B. Leighton, and M. Sands, *The Feynman Lectures on Physics*, AddisonWesley **1** (1964), 44,1–6.